

Pioneer

Service Manual

KEH-1800/X1M/EW

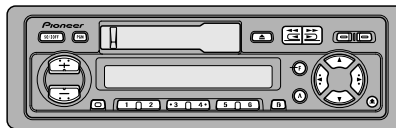

ORDER NO.
CRT2265

HIGH POWER CASSETTE PLAYER WITH FM/MW/LW TUNER

KEH-1800

KEH-1830

X1M/EW

X1M/EW

NOTE:

- See the separate manual CX-644(CRT1800) for the cassette mechanism description.
- The cassette mechanism assy employed in this model is one of 2M series.

CONTENTS

1. SAFETY INFORMATION.....	2	7. GENERAL INFORMATION.....	33
2. EXPLODED VIEWS AND PARTS LIST	2	7.1 PARTS	33
3. SCHEMATIC DIAGRAM.....	10	7.1.1 IC.....	33
4. PCB CONNECTION DIAGRAM.....	18	7.1.2 DISPLAY	37
5. ELECTRICAL PARTS LIST.....	26	7.2 DISASSEMBLY	38
6. ADJUSTMENT	31	7.3 BLOCK DIAGRAM	39
		8. OPERATIONS AND SPECIFICATIONS.....	40

PIONEER ELECTRONIC CORPORATION 4-1, Meguro 1-Chome, Meguro-ku, Tokyo 153-8654, Japan
PIONEER ELECTRONICS SERVICE INC. P.O.Box 1760, Long Beach, CA 90801-1760 U.S.A.
PIONEER ELECTRONIC [EUROPE] N.V. Haven 1087 Keetberglaan 1, 9120 Melsele, Belgium
PIONEER ELECTRONICS ASIACENTRE PTE.LTD. 253 Alexandra Road, #04-01, Singapore 159936

1. SAFETY INFORMATION

CAUTION

This service manual is intended for qualified service technicians; it is not meant for the casual do-it-yourselfer. Qualified technicians have the necessary test equipment and tools, and have been trained to properly and safely repair complex products such as those covered by this manual. Improperly performed repairs can adversely affect the safety and reliability of the product and may void the warranty. If you are not qualified to perform the repair of this product properly and safely; you should not risk trying to do so and refer the repair to a qualified service technician.

2. EXPLODED VIEWS AND PARTS LIST

2.1 PACKING

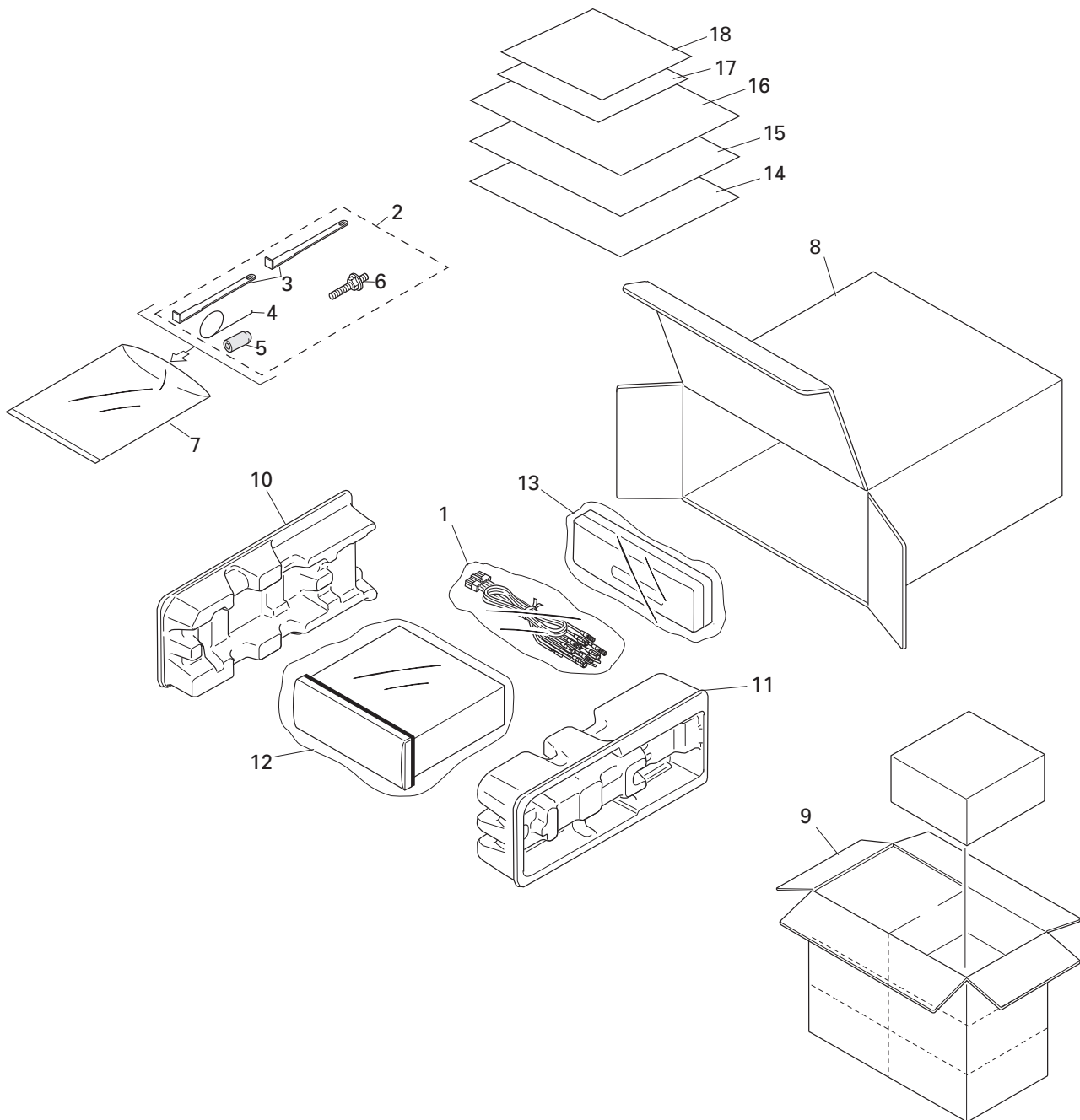

NOTE:

- Parts marked by "*" are generally unavailable because they are not in our Master Spare Parts List.
- Screws adjacent to ∇ mark on the product are used for disassembly.

● PACKING SECTION PARTS LIST

Mark No.	Description	Part.No	
		KEH-1800/X1M/EW	KEH-1830/X1M/EW
1	Cord Assy	CDE5807	CDE5807
2	Accessory Assy	CEA1917	CEA1917
3	Handle	CNC5395	CNC5395
4	Spring	CBH1650	CBH1650
5	Bush	CNV3930	CNV3930
6	Screw	CBA1304	CBA1304
* 7	Polyethylene Bag	E36-615	E36-615
8	Carton	CHG3621	CHG3622
9	Contain Box	CHL3621	CHL3622
10	Protector	CHP1622	CHP1622
11	Protector	CHP1623	CHP1623
12	Polyethylene Bag	CEG-162	CEG-162
13	Case Assy	CXB3520	CXB3520
14	Owner's Manual	CRD2810	CRD2810
15	Owner's Manual	CRD2811	CRD2811
16	Installation Manual	CRD2812	CRD2812
* 17	Passport	CRY1013	CRY1013
* 18	Warranty Card	CRY1087	CRY1087

● Owner's Manual, Installation Manual

Model	Part No.	Language
KEH-1800/X1M/EW	CRD2810	English,Spanish,Dutch
KEH-1830/X1M/EW	CRD2811	French,Italian,German
	CRD2812	English,Spanish,Dutch,French,Italian,German

2.2 EXTERIOR

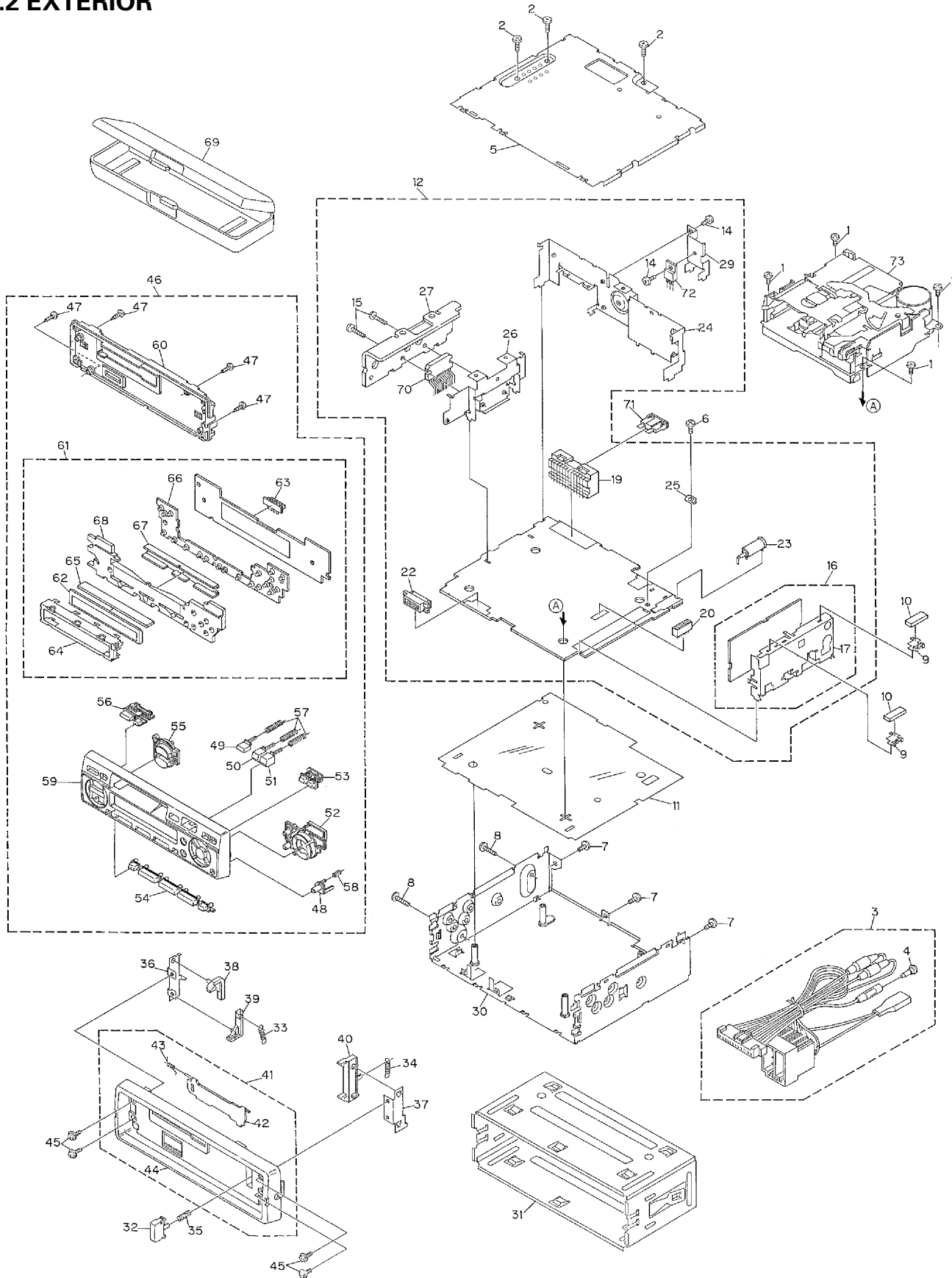

(1) EXTERIOR SECTION PARTS LIST

Mark No.	Description	Part No.	Mark No.	Description	Part No.
1	Screw	BSZ26P050FMC	41	Panel Unit	See Contrast table(2)
2	Screw	BSZ30P100FMC	42	Door	See Contrast table(2)
3	Cord Assy	CDE5807	43	Spring	CBH1838
4	Terminal Cover	CKX-003	44	Panel	See Contrast table(2)
5	Case	CNB2481	45	Screw	IMS20P030FZK
6	Screw	BSZ30P055FUC	46	Detach Grille Assy	See Contrast table(2)
7	Screw	BSZ30P060FMC	47	Screw	BPZ20P120FZK
8	Screw	BSZ30P100FMC	48	Button(Detachable)	See Contrast table(2)
9	Holder	CNC5704	49	Button(Eject)	See Contrast table(2)
10	Cushion	CNM4870	50	Button(REW)	See Contrast table(2)
11	Insulator	CNM5025	51	Button(FF)	See Contrast table(2)
12	Tuner Amp Unit	CWM6351	52	Button(F,A,Cross)	See Contrast table(2)
13		53	Button(-,-)	See Contrast table(2)
14	Screw	BSZ26P080FMC	54	Button(1-6,D,B)	See Contrast table(2)
15	Screw	BSZ26P140FMC	55	Button(+,-)	See Contrast table(2)
16	FM/AM Tuner Unit	CWE1466	56	Button(SO/OFF,PGM)	See Contrast table(2)
17	Holder	CNC6554	57	Spring	CBH1836
18		58	Spring	CBH2103
19	Plug(CN601)	CKM1270	59	Grille	See Contrast table(2)
20	Connector(CN604)	CKS3362	60	Cover	See Contrast table(2)
21		61	Keyboard Unit	See Contrast table(2)
22	Connector(CN603)	CKS3581	62	LCD(LCD901)	CAW1513
23	Antenna Jack(CN301)	CKX1056	63	Connector(CN901)	CKS3580
24	Panel	CNB2246	64	Holder	CNC8054
25	Holder	CNC5399	65	Connector	CNV5586
26	Holder	CNC6216	66	Rubber	CNV5587
27	Heat Sink	CNC6217	67	Holder	CNV5589
28		68	Lighting Conductor	CNV5752
29	Holder	CNC6845	69	Case Assy	CXB3520
30	Chassis Unit	See Contrast table(2)	70	IC(IC501)	TDA7384
31	Holder Unit	CXB2687	71	Fuse(10A)(FU951)	CEK1136
32	Button	CAC4836	72	Transistor(Q804)	2SD2396
33	Spring	CBH1834	73	Cassette Mechanism Assy	EXK3450
34	Spring	CBH1835			
35	Spring	CBH1996			
36	Bracket	CNC6135			
37	Bracket	CNC6791			
38	Arm	CNV4692			
39	Arm	CNV4693			
40	Arm	CNV4728			

(2) CONTRAST TABLE

KEH-1800/X1M/EW and KEH-1830/X1M/EW are constructed the same except for the following:

Mark	No.	Description	Part No.	
			KEH-1800/X1M/EW	KEH-1830/X1M/EW
	30	Chassis Unit	CXB3226	CXB3227
	41	Panel Unit	CXB3714	CXB3716
	42	Door	CAT2028	CAT2037
	44	Panel	CNS5211	CNS5212
	46	Detach Grille Assy	CXB3377	CXB3378
	48	Button(Detachable)	CAC5868	CAC5869
	49	Button(Eject)	CAC5870	CAC5871
	50	Button(REW)	CAC5872	CAC5873
	51	Button(FF)	CAC5874	CAC5875
	52	Button(Cross,A,F)	CAC5876	CAC5877
	53	Button(-,-)	CAC5878	CAC5879
	54	Button(D,B,1-6)	CAC5985	CAC5986
	55	Button(+,-)	CAC5882	CAC5883
	56	Button(SO/OFF,PGM)	CAC5884	CAC5885
	59	Grille	CNS5204	CNS5205
	60	Cover	CNS5209	CNS5210
	61	Keyboard Unit	CWM6273	CWM6275

2.3 CASSETTE MECHANISM ASSY

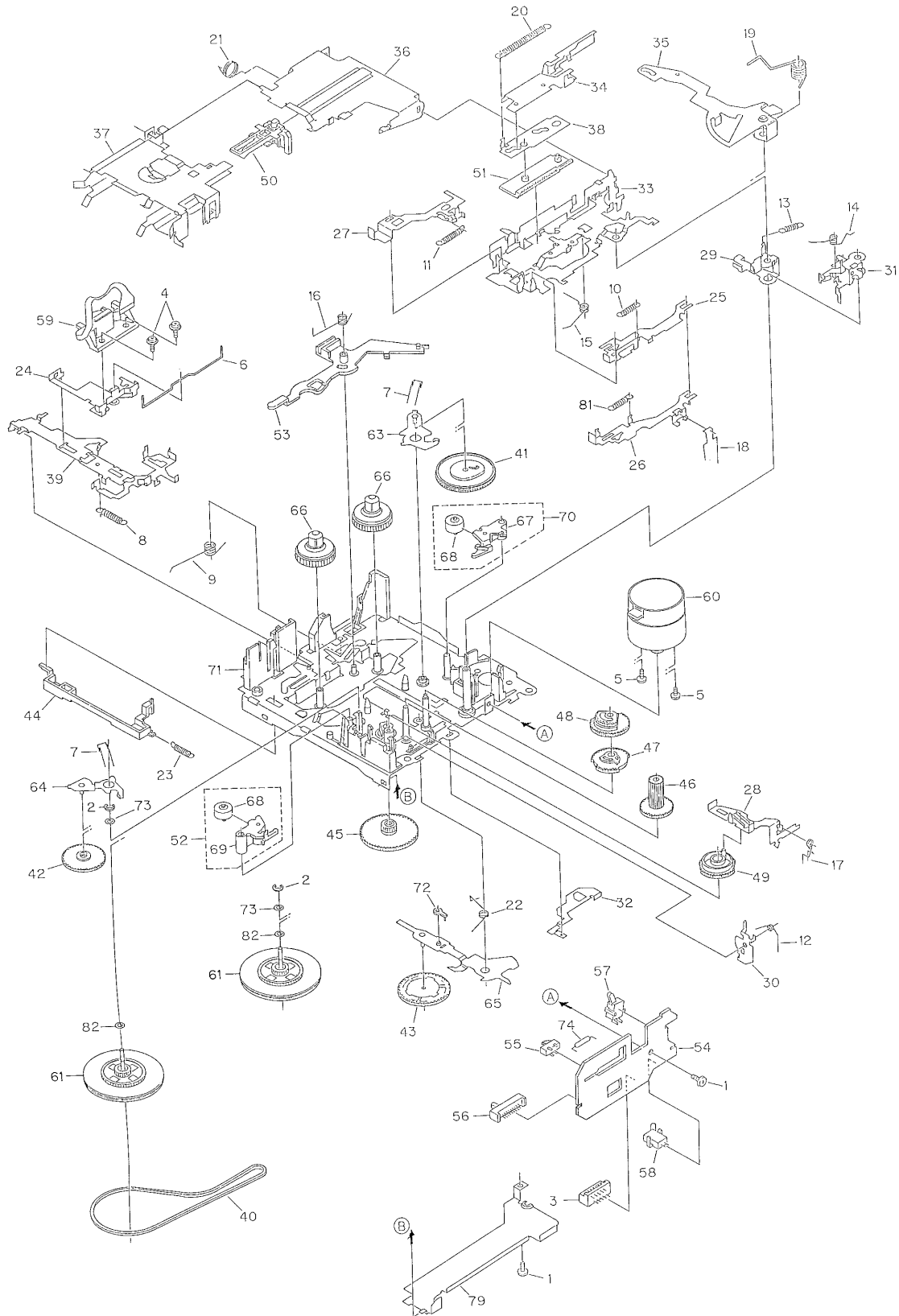

● CASSETTE MECHANISM ASSY SECTION PARTS LIST

Mark No.	Description	Part No.	Mark No.	Description	Part No.
1	Screw	BSZ23P050FMC	46	Gear	ENV1475
2	Washer	CBG1003	47	Gear	ENV1512
3	Connector(CN1)	CKS2829	48	Gear	ENV1513
4	Screw(M2x5)	EBA1038	49	Gear	ENV1502
5	Screw(M2x2.5)	EBA1037	50	Lever	ENV1480
6	Spring	EBH1554	51	Lever	ENV1487
7	Spring	EBH1555	52	Pinch Holder Unit	EXA1516
8	Spring	EBH1556	53	Arm	ENV1519
9	Spring	EBH1603	* 54	PCB	ENP1161
10	Spring	EBH1591	55	Switch(Eject)(S4)	ESG1006
11	Spring	EBH1559	56	Switch(FWD)(REV)(S3)	ESH1006
12	Spring	EBH1593	57	Switch(Load)(S1)	ESN1016
13	Spring	EBH1561	58	Switch(Mute)(S2)	ESN1017
14	Spring	EBH1562	59	Head Assy(HD1)	EXA1466
15	Spring	EBH1563	60	Motor Unit(M1)	EXA1467
16	Spring	EBH1590	61	Flywheel Unit	EXA1547
17	Spring	EBH1565	62	
18	Spring	EBH1566	63	Arm Unit	EXA1447
19	Spring	EBH1567	64	Arm Unit	EXA1448
20	Spring	EBH1568	65	Arm Unit	EXA1550
21	Spring	EBH1569	66	Reel Unit	EXA1450
22	Spring	EBH1571	67	Pinch Holder	ENV1466
23	Spring	EBH1579	68	Pinch Roller	ENV1518
24	Head Base	ENC1475	69	Pinch Holder	ENV1467
25	Lever	ENC1429	70	Pinch Holder Unit	EXA1515
26	Lever	ENC1430	71	Chassis Unit	EXA1498
27	Lever	ENC1431	72	Arm	ENV1524
28	Lever	ENC1432	73	Washer	CBF-167
29	Arm	ENC1433	74	Resistor(R1)	RD1/4HM472J
30	Arm	ENC1434	75-78	
31	Arm	ENC1480	79	Cover	ENC1452
32	Arm	ENC1476	80	
33	Bracket	ENC1512	81	Spring	EBH1592
34	Lever	ENC1523	82	Washer	CBF1051
35	Arm	ENC1524			
36	Frame	ENC1440			
37	Holder	ENC1441			
38	Lever	ENC1446			
39	Lever	ENC1478			
40	Belt	ENT1027			
41	Gear	ENV1504			
42	Gear	ENV1470			
43	Gear	ENV1517			
44	Lever	ENV1472			
45	Gear	ENV1510			

3. SCHEMATIC DIAGRAM

3.1 OVERALL CONNECTION DIAGRAM(GUIDE PAGE)

Note: When ordering service parts, be sure to refer to "EXPLODED VIEWS AND PARTS LIST" or "ELECTRICAL PARTS LIST".

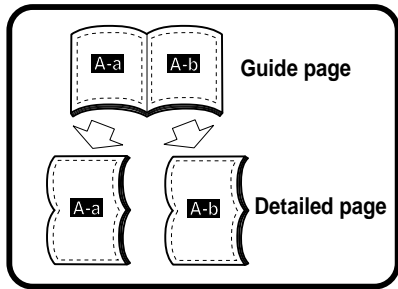
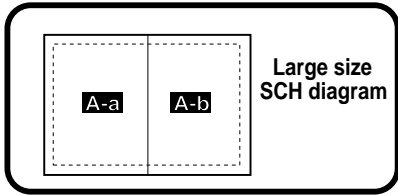

A-a

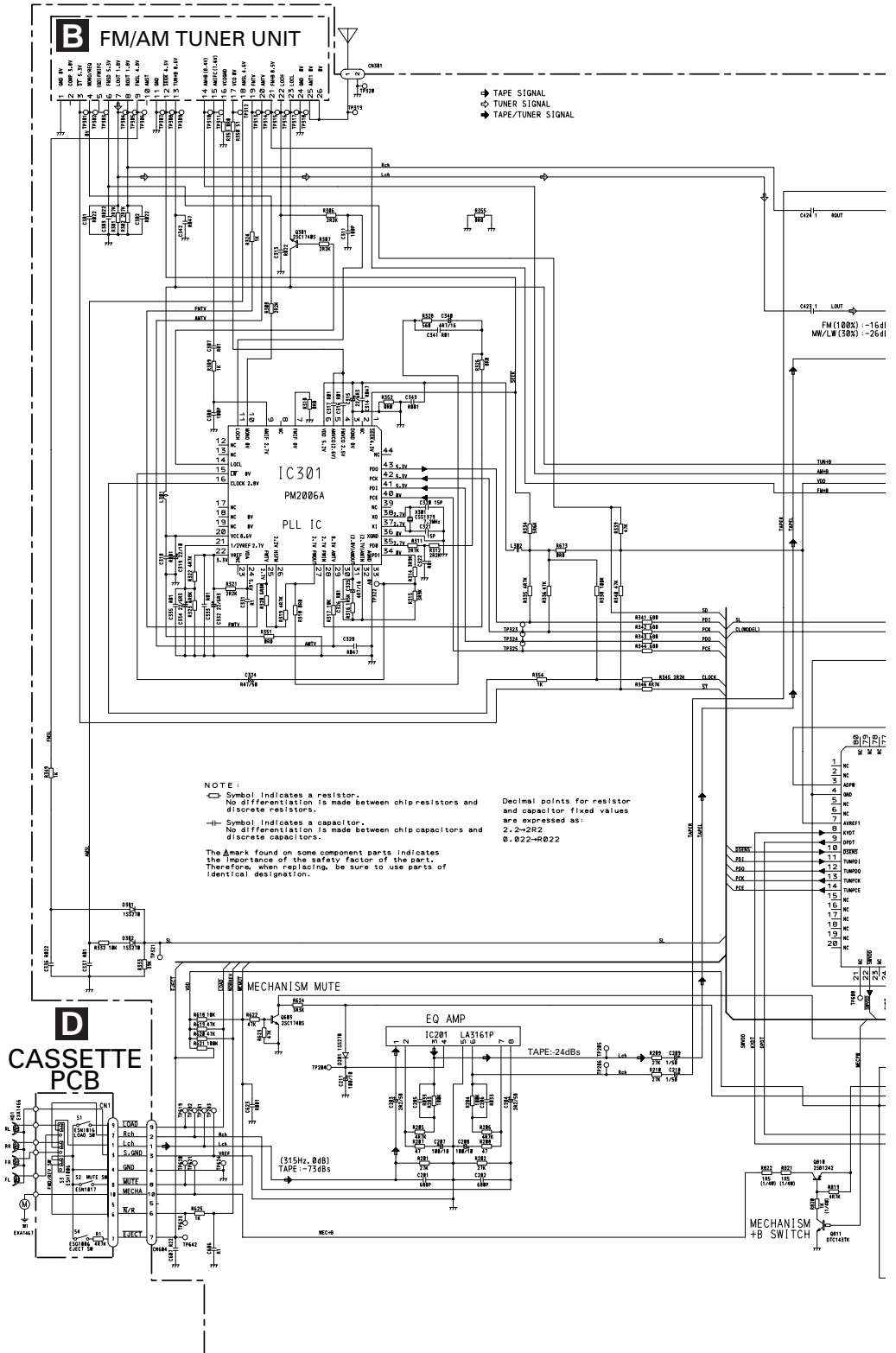

A-b

A TUNER AMP UNIT

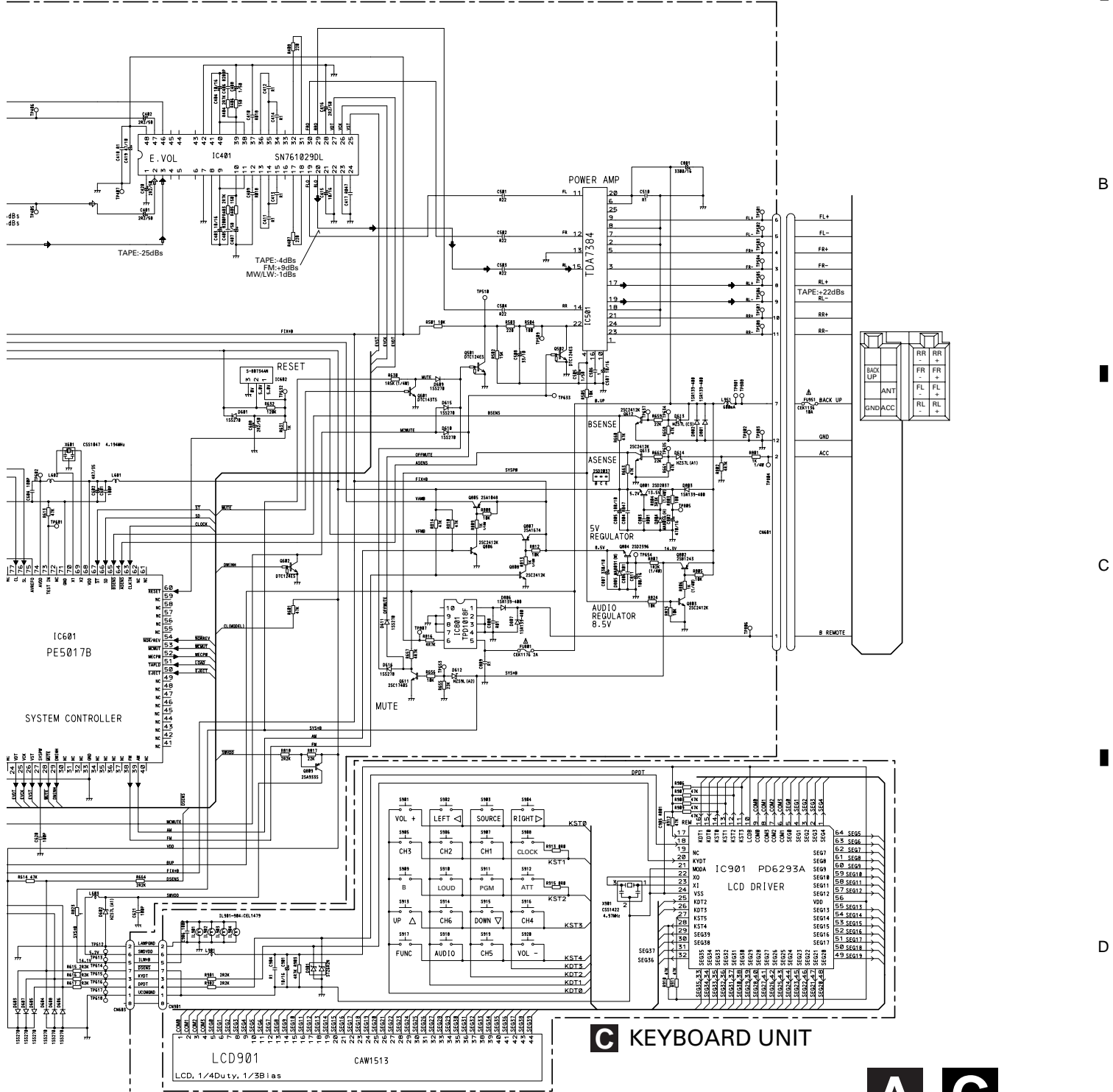

C KEYBOARD UNIT

A

C

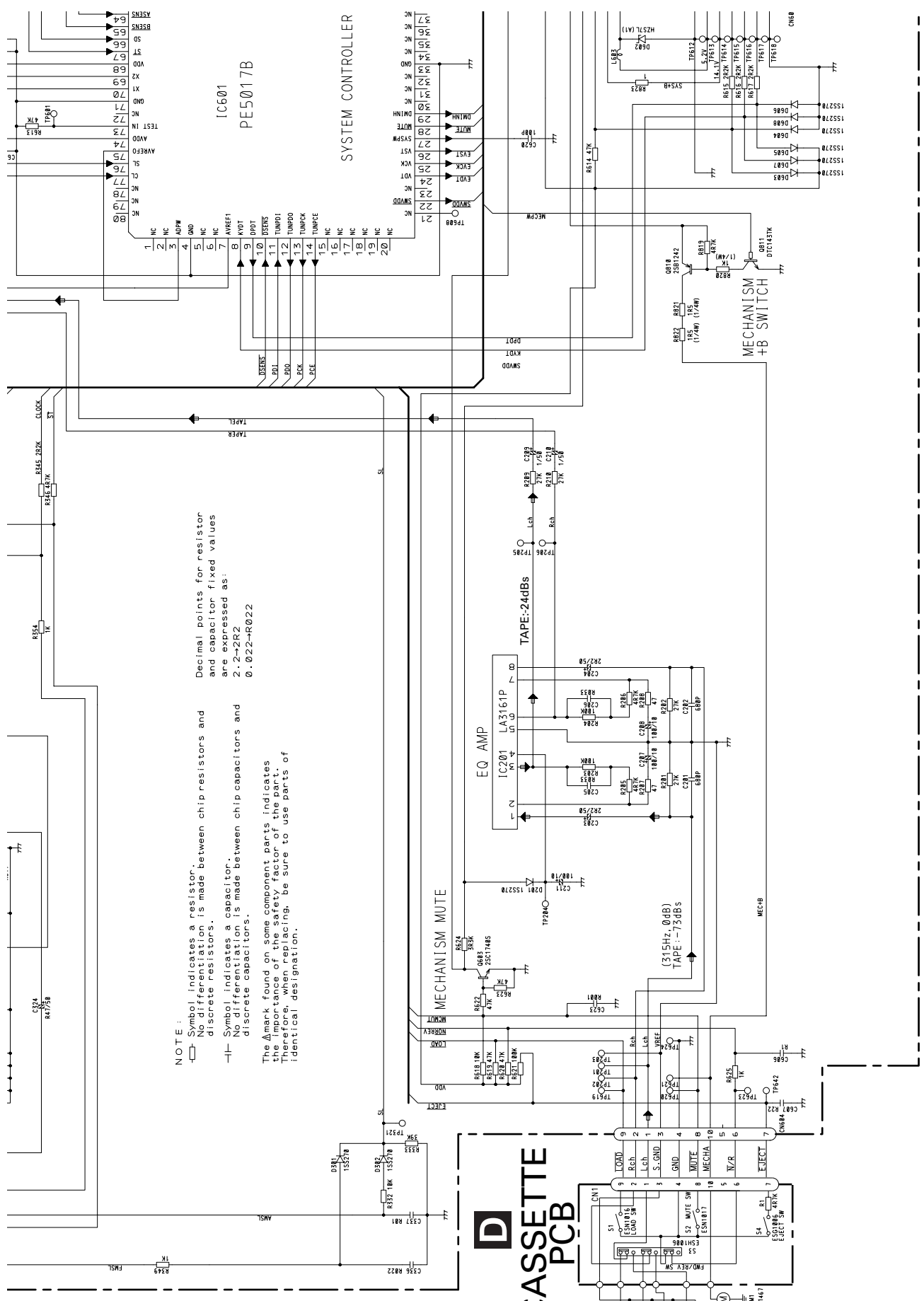

NOTE:

- Symbol indicates a resistor. No differentiation is made between chip resistors and discrete resistors.
- Symbol indicates a capacitor. No differentiation is made between chip capacitors and discrete capacitors.

The Δ mark found on some component parts indicates that the part is a reference part of the design. Therefore, when replacing, be sure to use parts of identical designation.

Decimal points for resistor and capacitor fixed values are expressed as:
 2.2→2R2
 0.022→R022

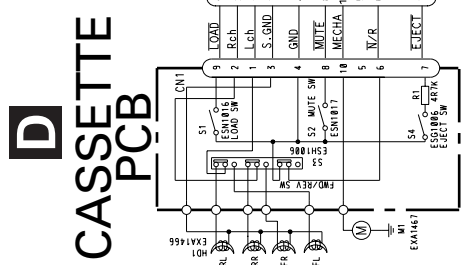

A-a A-b

A-a D

A-a A-b

A TUNER AMP UNIT

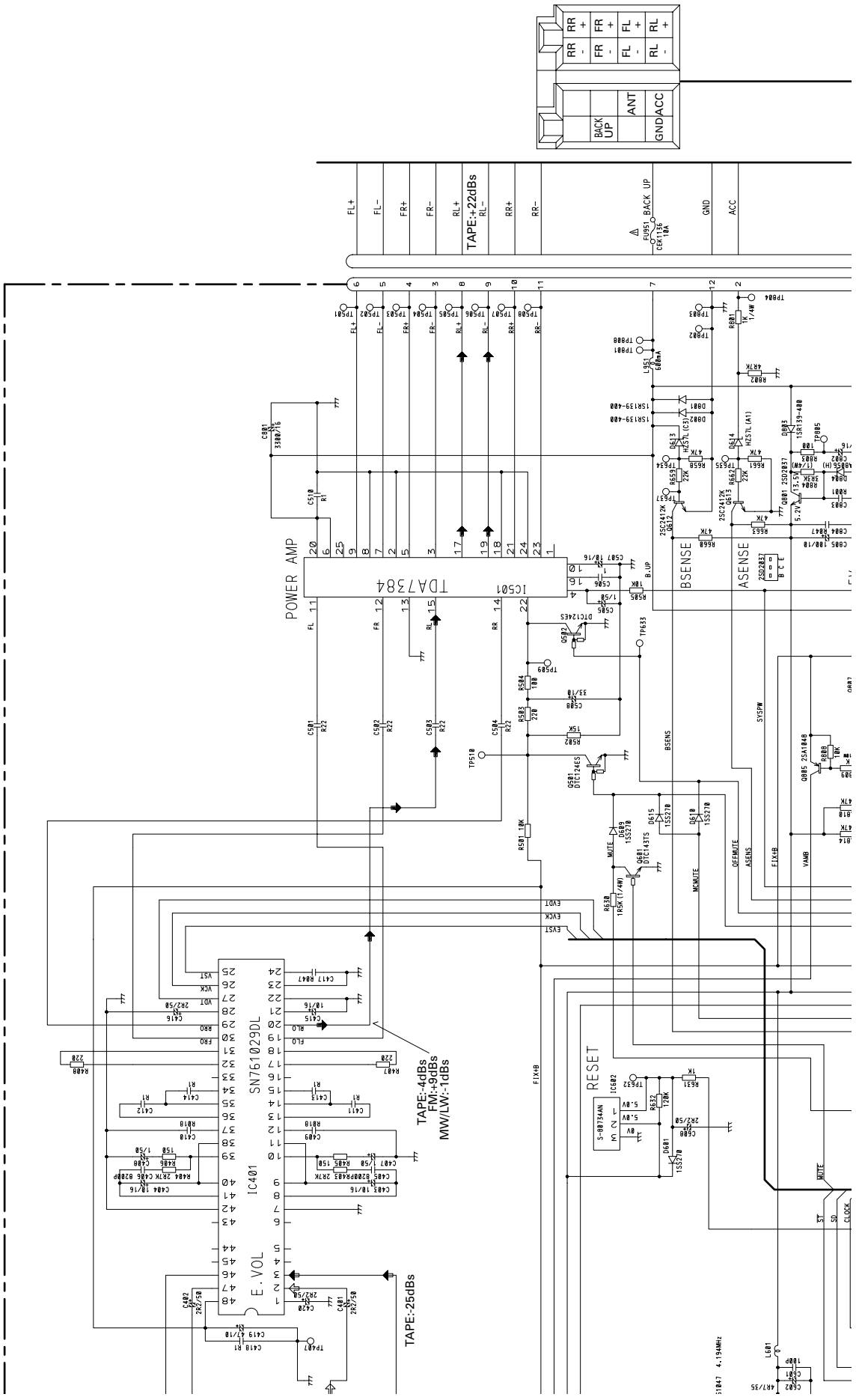

A-b

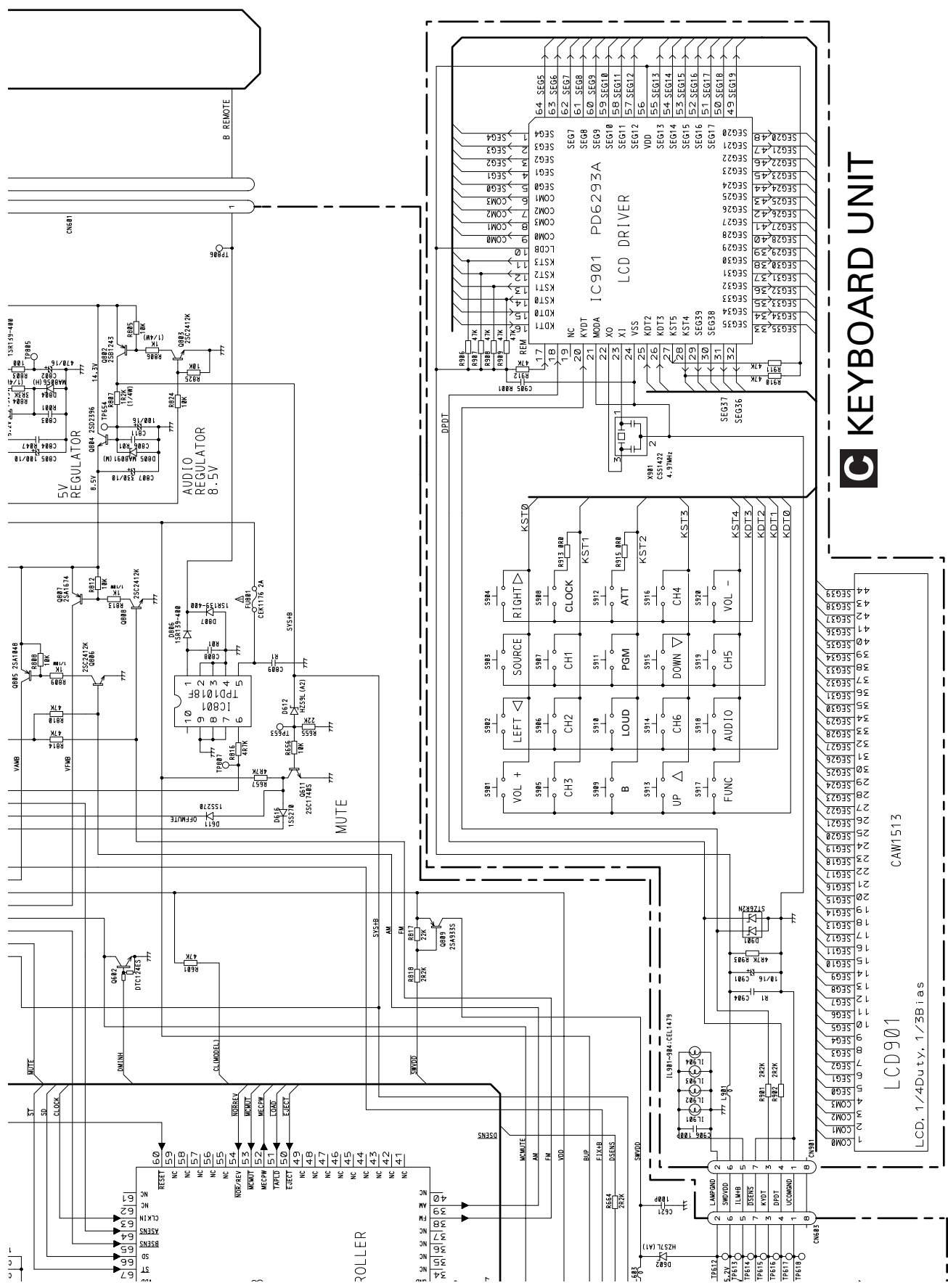

3.2 FM/AM TUNER UNIT

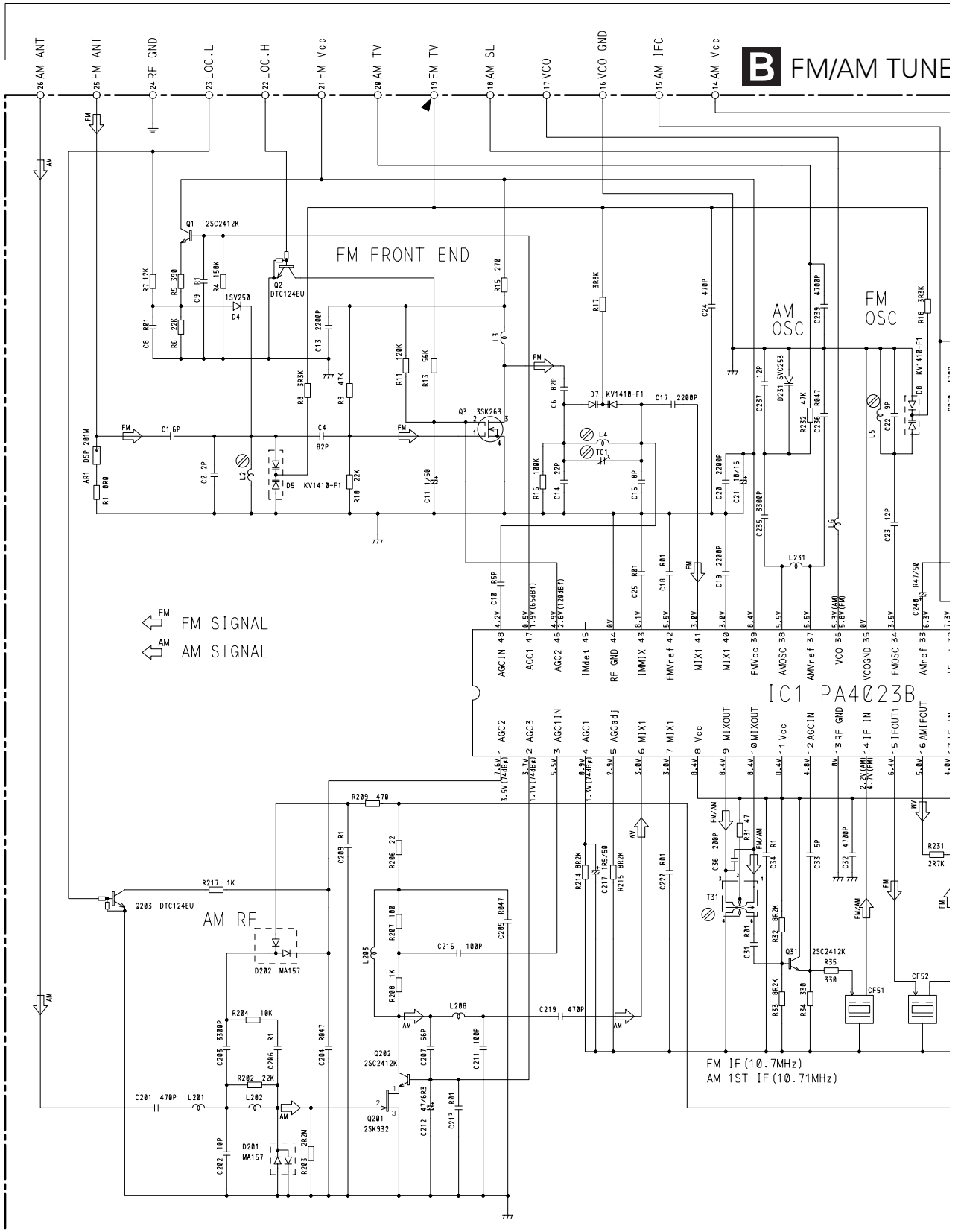

B FM/AM TUNE

B

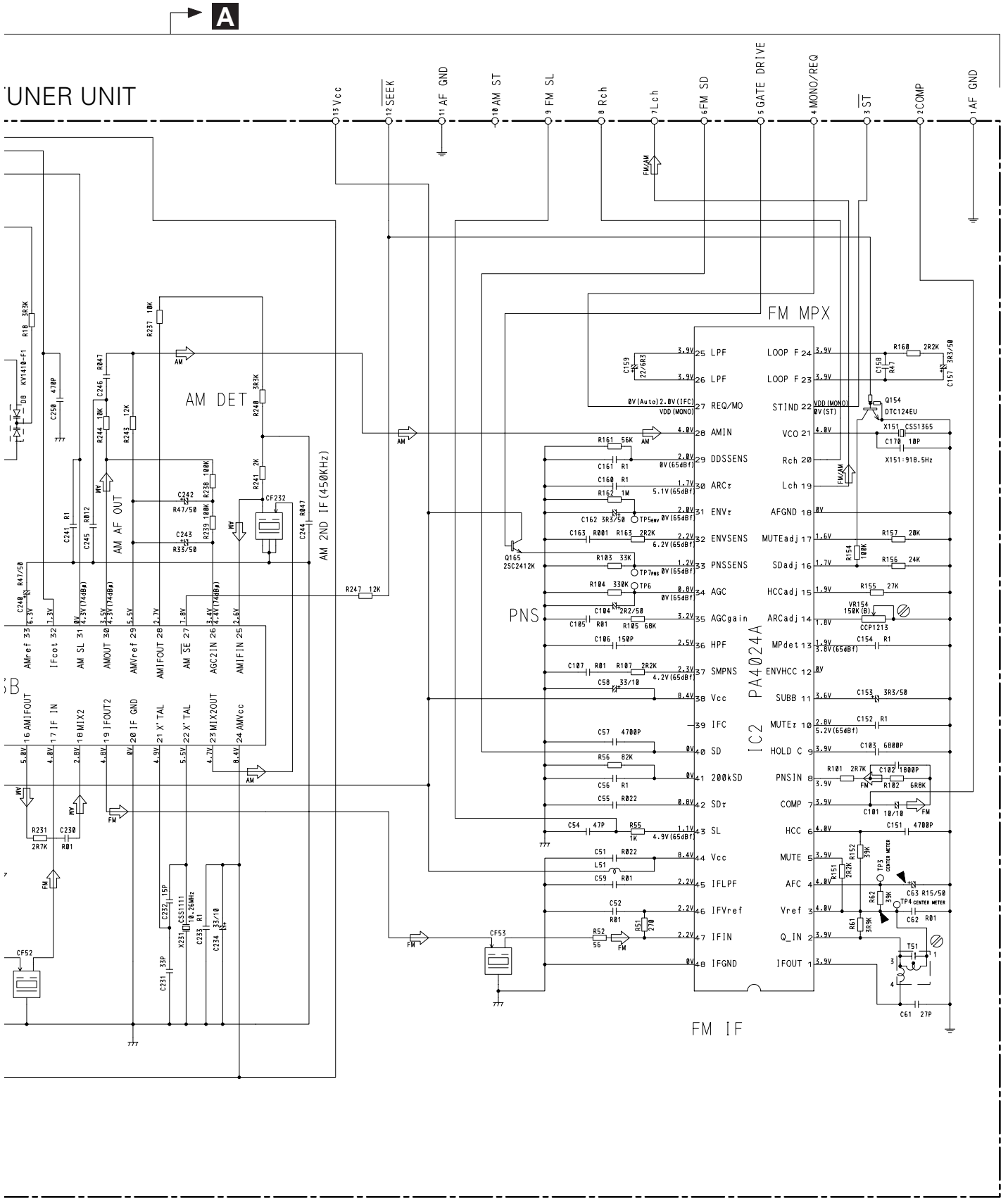

A

B

SIDE A

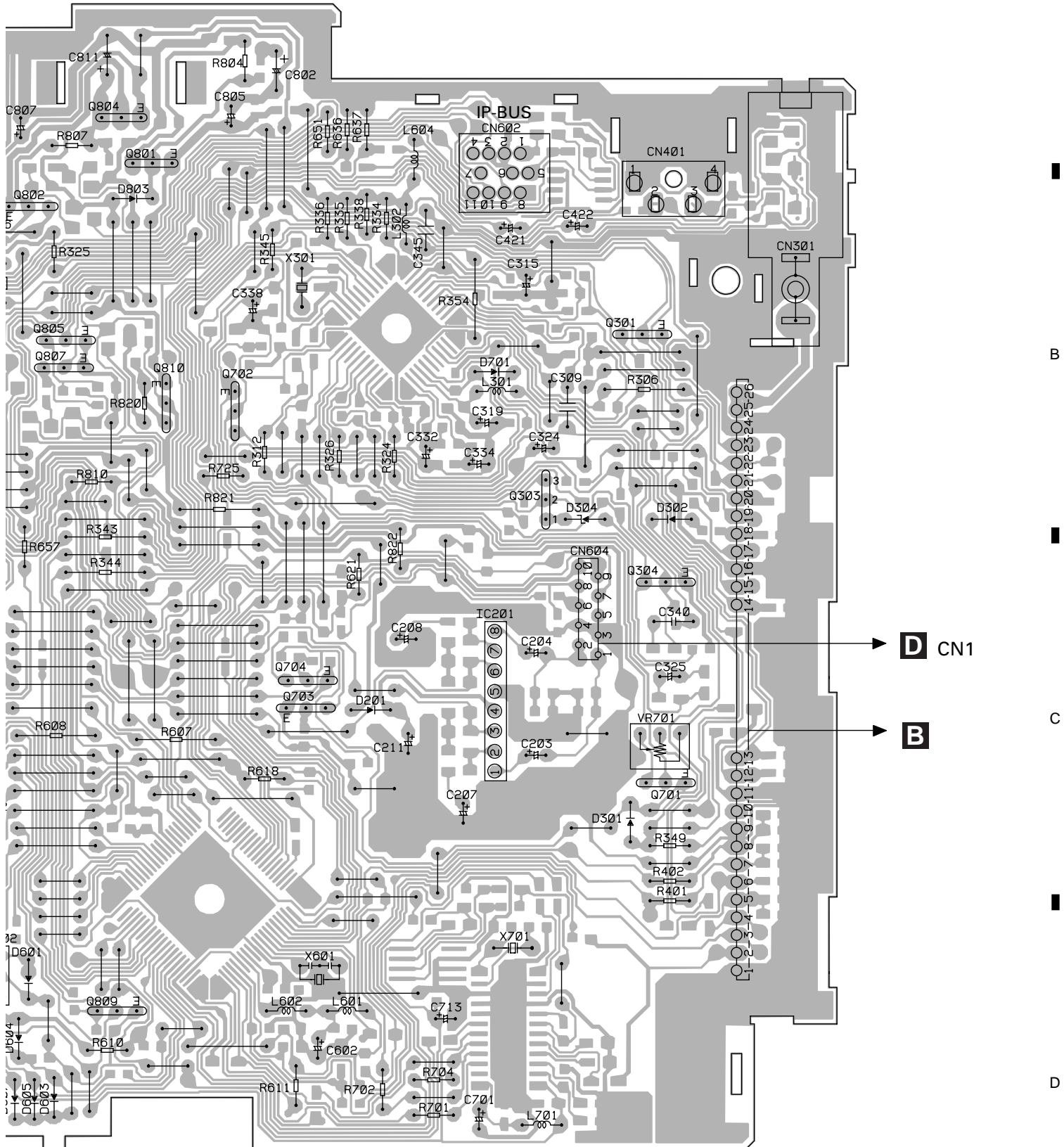

D CN1

B

A

A TUNER AMP UNIT

A

B

C

D

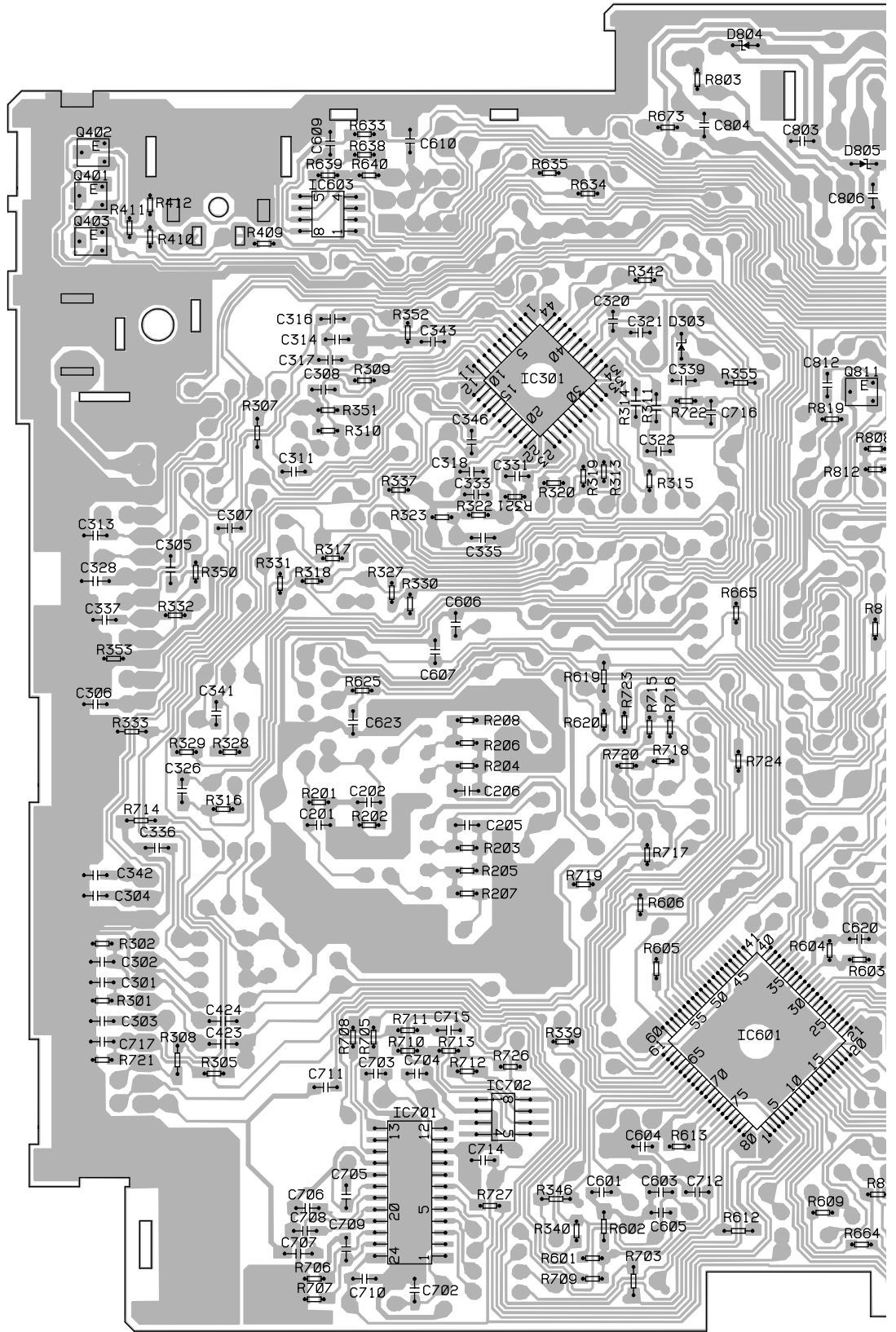

SIDE B

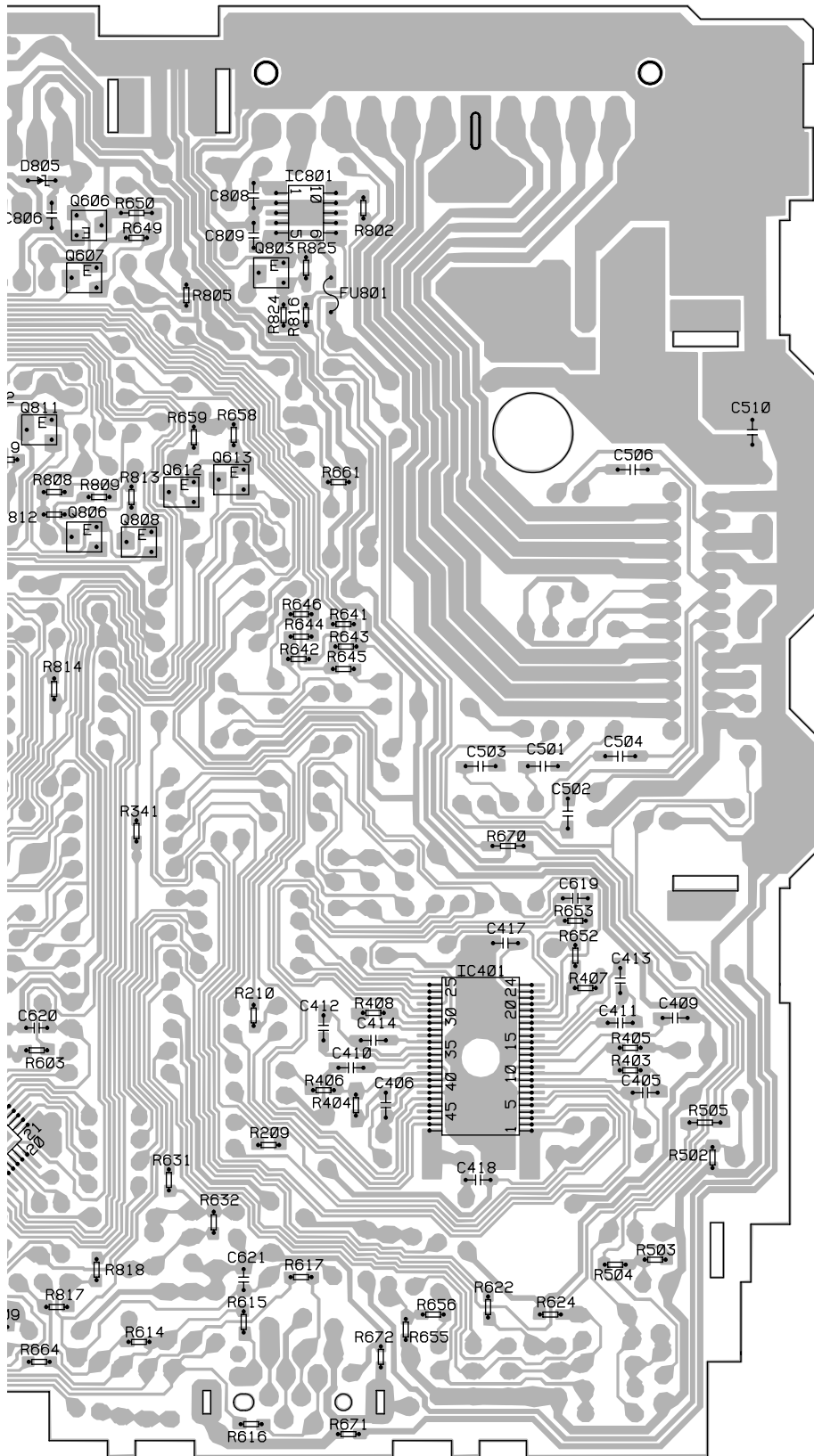

- IC, Q
- Q402
- IC801 Q606
- Q401 IC603
- Q403
- Q607 Q803
- Q811
- IC301
- Q613
- Q612
- Q806 Q808
- IC401
- IC601
- IC702
- IC701

A

B

C

D

4.2 FM/AM TUNER UNIT

SIDE A

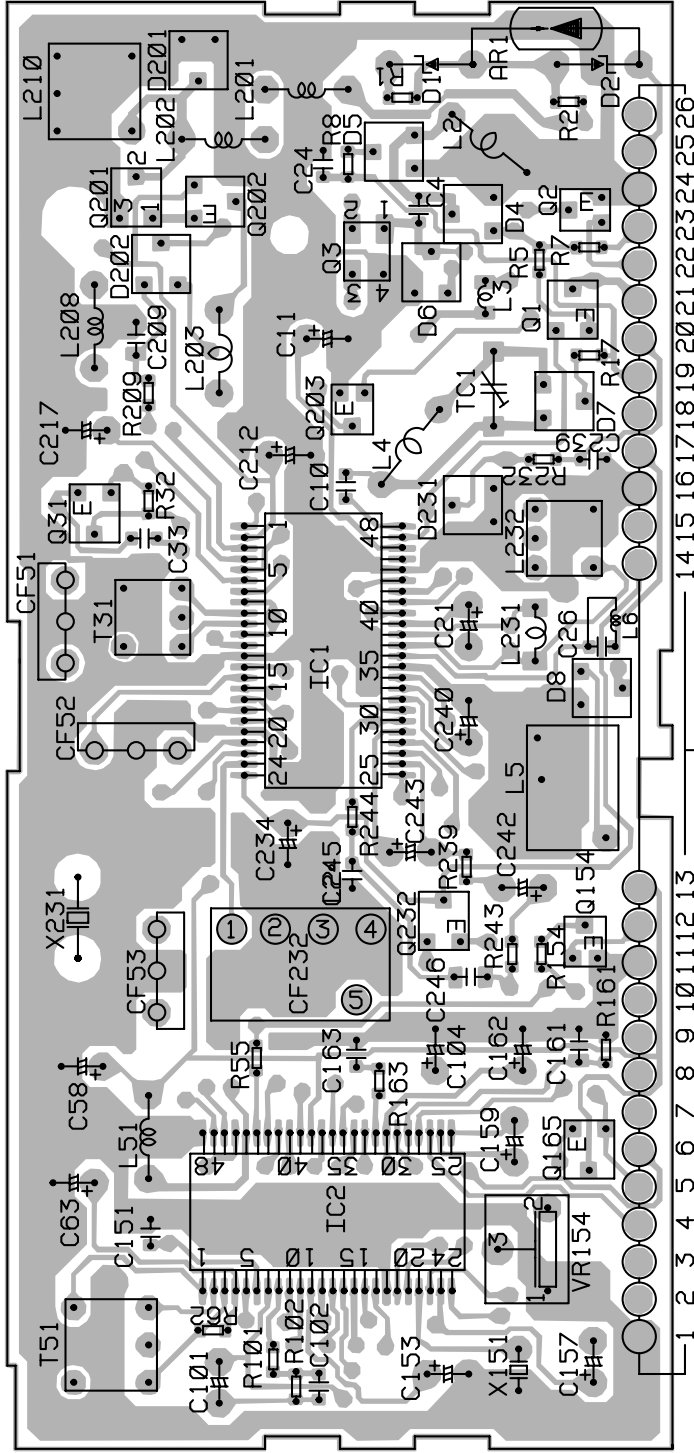

B FM/AM TUNER UNIT

- IC, Q
- ADJ
- T51
- T31
- Q202
- Q203
- Q3
- IC2
- IC1
- Q232
- L4
- L2
- TC1
- L5
- VR154
- Q1
- Q2
- Q154

A



SIDE B

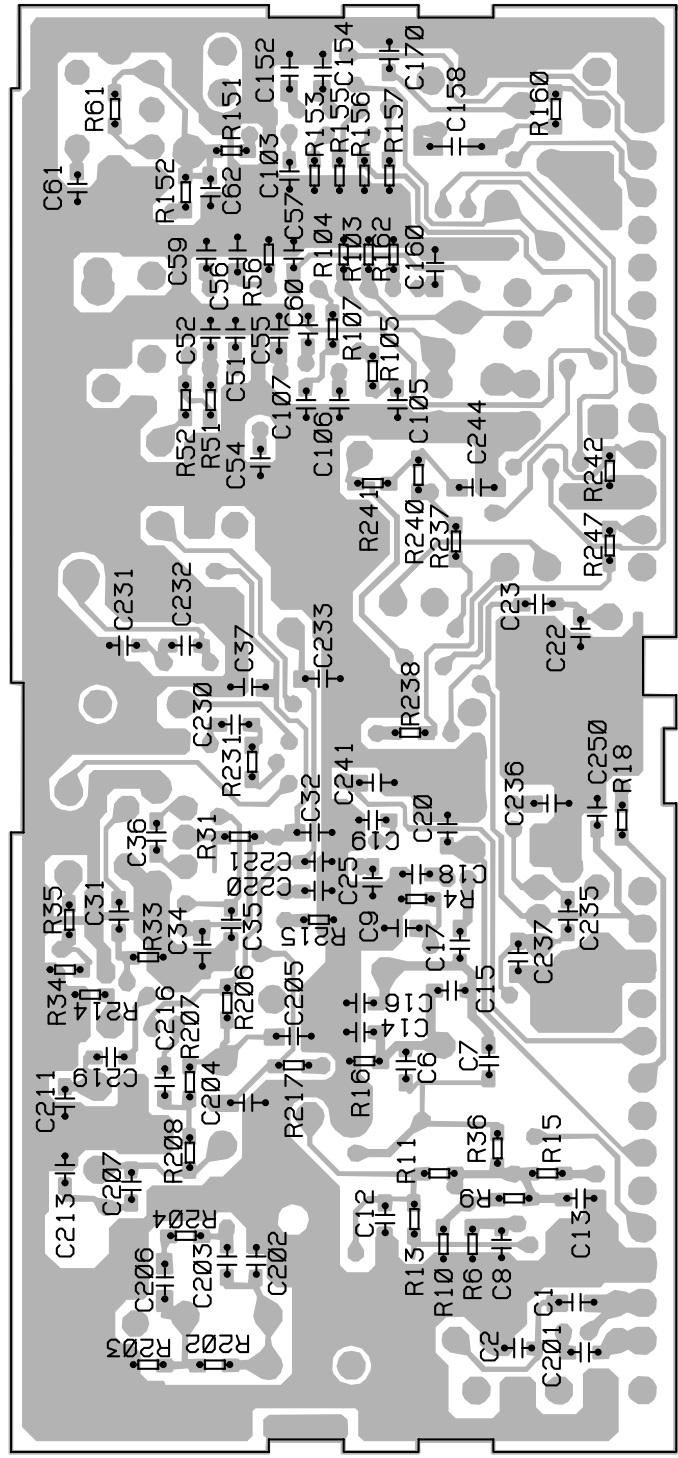

B FM/AM TUNER UNIT

B

4.3 KEYBOARD UNIT

SIDE A

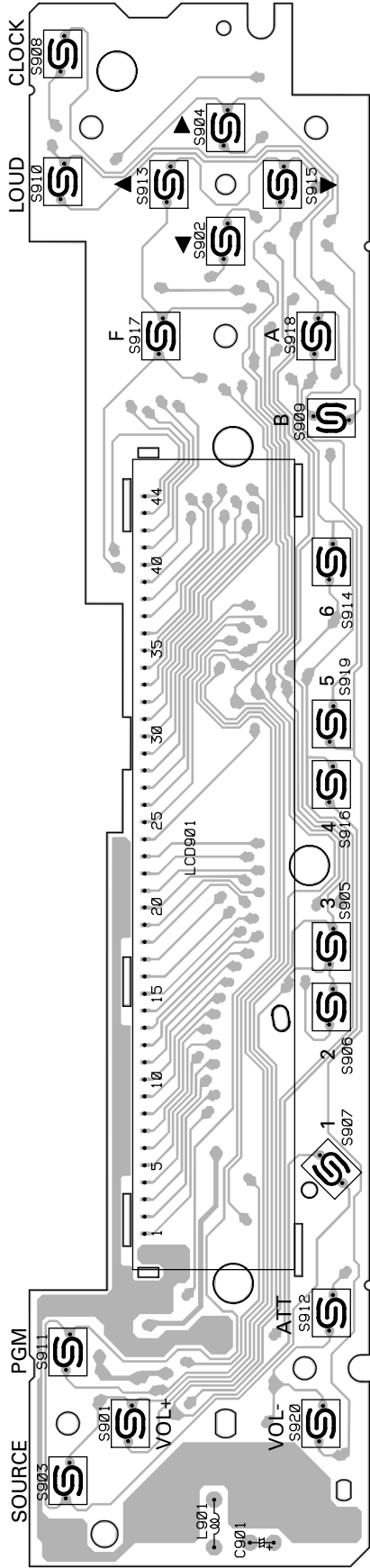

IC-0

IC901

SIDE B

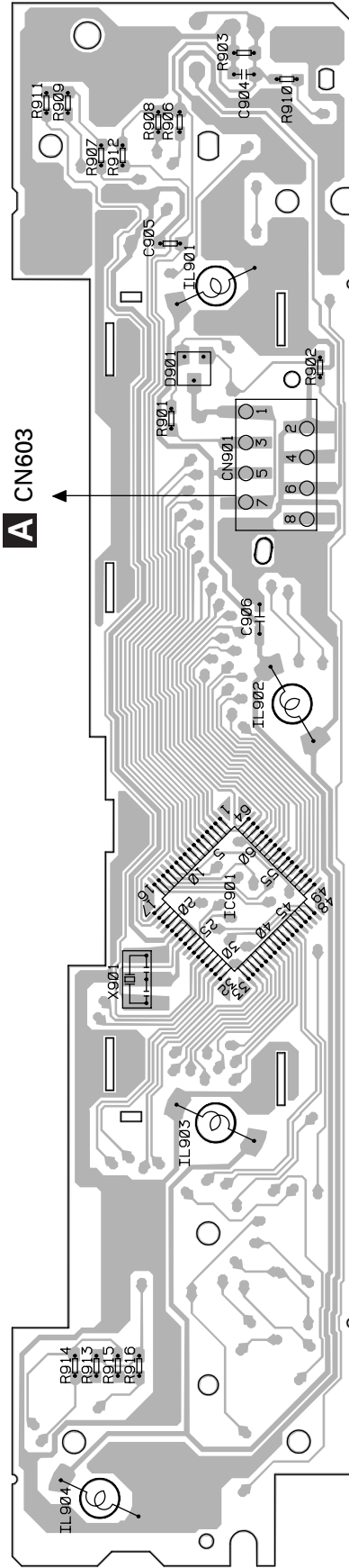

A CN603

C KEYBOARD UNIT

C KEYBOARD UNIT

4.4 CASSETTE MECHANISM ASSY

D CASSETTE PCB

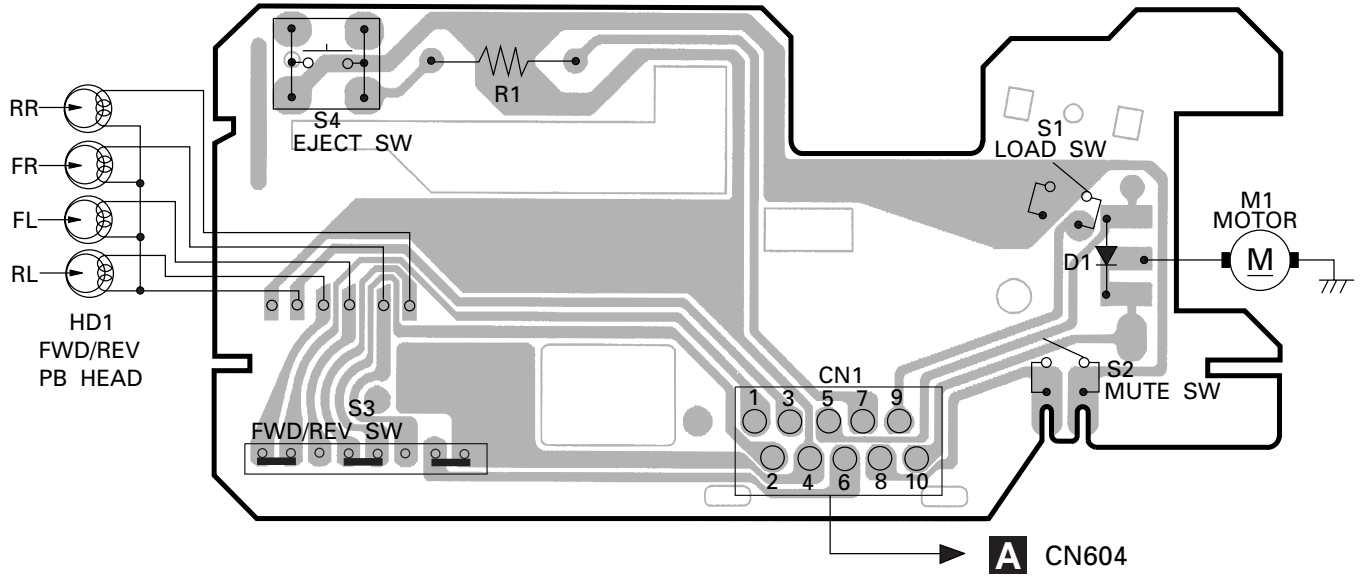

5. ELECTRICAL PARTS LIST

NOTE:

● Parts whose parts numbers are omitted are subject to being not supplied.

● The part numbers shown below indicate chip components.

Chip Resistor

RS1/○S○○○○J,RS1/○○S○○○J

Chip Capacitor (except for CQS.....)

CKS....., CCS....., CSZS.....

====Circuit Symbol and No.====Part Name	Part No.	====Circuit Symbol and No.====Part Name	Part No.
A Unit Number : CWM6351		D 805 Diode	MA8091(M)
Unit Name : Tuner Amp Unit		D 806 Diode	1SR139-400
MISCELLANEOUS		D 807 Diode	1SR139-400
IC 201 IC	LA3161P	L 301 Ferri-Inductor	LAU101K
IC 301 IC	PM2006A	L 302 Ferri-Inductor	LAU2R2K
IC 401 IC	SN761029DL	L 601 Ferri-Inductor	LAU101K
IC 501 IC	TDA7384	L 602 Ferri-Inductor	LAU101K
IC 601 IC	PE5017B	L 603 Ferri-Inductor	LAU101K
IC 602 IC	S-80734AN	L 951 Choke Coil 600mH	CTH1168
IC 801 IC	TPD1018F	X 301 Crystal Resonator 7.200MHz	CSS1379
Q 301 Transistor	2SC1740S	X 601 Ceramic Resonator 4.194MHz	CSS1047
Q 501 Transistor	DTC124ES	FU 801 Fuse 2A	CEK1176
Q 502 Transistor	DTC124ES	FM/AM Tuner Unit	CWE1466
Q 601 Transistor	DTC143TS	RESISTORS	
Q 602 Transistor	DTC124ES	R 201	RS1/10S273J
Q 603 Transistor	2SC1740S	R 202	RS1/10S273J
Q 611 Transistor	2SC1740S	R 203	RS1/10S104J
Q 612 Transistor	2SC2412K	R 204	RS1/10S104J
Q 613 Transistor	2SC2412K	R 205	RS1/10S472J
Q 801 Transistor	2SD2037	R 206	RS1/10S472J
Q 802 Transistor	2SB1243	R 207	RS1/10S470J
Q 803 Transistor	2SC2412K	R 208	RS1/10S470J
Q 804 Transistor	2SD2396	R 209	RS1/10S273J
Q 805 Transistor	2SA1048	R 210	RS1/10S273J
Q 806 Transistor	2SC2412K	R 301	RS1/10S272J
Q 807 Transistor	2SA1674	R 302	RS1/10S272J
Q 808 Transistor	2SC2412K	R 305	RS1/10S0R0J
Q 809 Transistor	2SA933S	R 306	RD1/4PU222J
Q 810 Transistor	2SB1242	R 307	RS1/8S222J
Q 811 Transistor	DTC143TK	R 308	RS1/8S222J
D 201 Diode	1SS270	R 309	RS1/10S102J
D 301 Diode	1SS270	R 310	RS1/10S0R0J
D 302 Diode	1SS270	R 311	RS1/8S272J
D 601 Diode	1SS270	R 312	RD1/4PU222J
D 602 Diode	HZS7L(A1)	R 314	RS1/8S392J
D 603 Diode	1SS270	R 315	RS1/10S392J
D 604 Diode	1SS270	R 316	RS1/10S152J
D 605 Diode	1SS270	R 317	RS1/10S103J
D 606 Diode	1SS270	R 318	RS1/10S0R0J
D 607 Diode	1SS270	R 319	RS1/10S472J
D 608 Diode	1SS270	R 320	RS1/10S682J
D 609 Diode	1SS270	R 321	RS1/10S222J
D 610 Diode	1SS270	R 322	RS1/10S472J
D 611 Diode	1SS270	R 323	RS1/10S682J
D 612 Diode	HZS9L(A2)	R 324	RD1/4PU102J
D 613 Diode	HZS7L(C3)	R 326	RD1/4PU0R0J
D 614 Diode	HZS7L(A1)	R 328	RS1/10S561J
D 615 Diode	1SS270	R 332	RS1/10S103J
D 616 Diode	1SS270	R 333	RS1/8S393J
D 801 Diode	1SR139-400	R 334	RD1/4PU562J
D 802 Diode	1SR139-400	R 335	RD1/4PU472J
D 803 Diode	1SR139-400	R 336	RD1/4PU473J
D 804 Diode	MA8056(H)	R 338	RD1/4PU104J
		R 339	RS1/10S473J

====Circuit Symbol and No.====Part Name	Part No.
C 414	CKSQYB104K16
C 415	CEJA100M16
C 416	CEJA2R2M50
C 417	CKSQYB473K50
C 418	CKSQYB104K16
C 419	CEJA470M10
C 420	CEJA2R2M50
C 423	CKSYB105K16
C 424	CKSYB105K16
C 501	CKSYB224K16
C 502	CKSYB224K16
C 503	CKSYB224K16
C 504	CKSYB224K16
C 505	CEJA1R0M50
C 506	CKSYB105K16
C 507	CEJA100M16
C 508	CEJA330M10
C 510	CKSQYB104K16
C 601	CCSQCH101J50
C 602	CEJA4R7M35
C 604	CCSQCH101J50
C 606	CKSQYB104K16
C 607	CKSQYB224K16
C 608	CEJA2R2M50
C 620	CCSQCH101J50
C 621	CCSQCH101J50
C 623	CKSQYB102K50
C 801 3300µF/16V	CCH1018
C 802 470µF/16V	CCH1183
C 803	CKSQYB102K50
C 804	CKSQYB473K50
C 805	CEJA101M10
C 806	CKSQYB103K50
C 807 330µF/10V	CCH1181
C 808	CKSQYB103K50
C 809	CKSQYB104K16
C 811 100µF/16V	CCH1179

C Unit Number : CWM6273(KEH-1800/X1M/EW)
Unit Name : Keyboard Unit

MISCELLANEOUS

IC 901	IC	PD6293A
D 901	Diode	STZ6R2N
L 901	Ferri-Inductor	LAU101K
X 901	Ceramic Resonator 4.97MHz	CSS1422
IL 901	Lamp 14V 40mA	CEL1547
IL 902	Lamp 14V 40mA	CEL1547
IL 903	Lamp 14V 40mA	CEL1547
IL 904	Lamp 14V 40mA	CEL1547
LCD 901	LCD	CAW1513

RESISTORS

R 901	RS1/10S222J
R 902	RS1/10S222J
R 903	RS1/10S472J
R 906	RS1/10S473J
R 907	RS1/10S473J
R 908	RS1/10S473J
R 909	RS1/10S473J
R 910	RS1/10S473J
R 911	RS1/10S473J
R 912	RS1/10S473J
R 913	RS1/10S0R0J
R 915	RS1/10S0R0J

====Circuit Symbol and No.====Part Name	Part No.
CAPACITORS	
C 901	CEAL100M16
C 904	CKSQYB104K16
C 905	CKSQYB102K50
C 906	CCSCH101J50

C Unit Number : CWM6275(KEH-1830/X1M/EW)
Unit Name : Keyboard Unit

MISCELLANEOUS

IC 901	IC	PD6293A
D 901	Diode	STZ6R2N
L 901	Ferri-Inductor	LAU101K
X 901	Ceramic Resonator 4.97MHz	CSS1422
IL 901	Lamp 8V 100mA	CEL1479
IL 902	Lamp 8V 100mA	CEL1479
IL 903	Lamp 8V 100mA	CEL1479
IL 904	Lamp 8V 100mA	CEL1479
LCD 901	LCD	CAW1513

RESISTORS

R 901	RS1/10S222J
R 902	RS1/10S222J
R 903	RS1/10S472J
R 906	RS1/10S473J
R 907	RS1/10S473J
R 908	RS1/10S473J
R 909	RS1/10S473J
R 910	RS1/10S473J
R 911	RS1/10S473J
R 912	RS1/10S473J
R 913	RS1/10S0R0J
R 915	RS1/10S0R0J

CAPACITORS

C 901	CEAL100M16
C 904	CKSQYB104K16
C 905	CKSQYB102K50
C 906	CCSCH101J50

B Unit Number : CWE1466
Unit Name : FM/AM Tuner Unit

MISCELLANEOUS

IC 1	IC	PA4023B
IC 2	IC	PA4024A
Q 1	Transistor	2SC2412K
Q 2	Transistor	DTC124EU
Q 3	FET	3SK263
Q 31	Transistor	2SC2412K
Q 154	Transistor	DTC124EU
Q 165	Transistor	2SC2412K
Q 201	FET	2SK932
Q 202	Transistor	2SC2412K
Q 203	Transistor	DTC124EU
D 4	Diode	1SV250
D 5	Diode	KV1410-F1
D 7	Diode	KV1410-F1
D 8	Diode	KV1410-F1
D 201	Diode	MA157
D 202	Diode	MA157
D 231	Diode	SVC253
L 2	Coil	CTC1133
L 3	Inductor	LCTB2R2K2125
L 4	Coil	CTC1133
L 5	Coil	CTC1132
L 6	Inductor	LCTBR15K1608
L 51	Ferri-Inductor	LAU150K
L 201	Ferri-Inductor	LAU4R7K

====Circuit Symbol and No.====Part Name	Part No.	====Circuit Symbol and No.====Part Name	Part No.
L 202 Ferri-Inductor	LAU330K	R 217	RS1/16S102J
L 203 Inductor	CTF1287	R 231	RS1/16S272J
L 208 Inductor	LAU121K	R 232	RS1/16S473J
L 231 Inductor	LCTA3R3J3225	R 237	RS1/16S103J
T 31 Coil	CTE1116	R 238	RS1/16S104J
T 51 Coil	CTC1136	R 239	RS1/16S104J
TC 1 Trimmer	CCL1046	R 240	RS1/16S332J
CF 51 Ceramic Filter	CTF1442	R 241	RS1/16S202J
CF 52 Ceramic Filter	CTF1442	R 243	RS1/16S123J
CF 53 Ceramic Filter	CTF1442	R 244	RS1/16S103J
CF 232 Ceramic Filter	CTF1348	R 247	RS1/16S123J
X 151 Radiator 918.5Hz	CSS1365		
X 231 Crystal Resonator 10.26MHz	CSS1111		
VR 154 Semi-fixed 150kΩ(B)	CCP1213		
AR 1 Capacitor with Discharge Gap	DSP-201M		
RESISTORS		CAPACITORS	
R 1	RS1/16S0R0J	C 1	CCSQCH6R0D50
R 4	RS1/16S154J	C 2	CCSRCK2R0C50
R 5	RS1/16S391J	C 4	CCSRCH820J50
R 6	RS1/16S223J	C 6	CCSRCH820J50
R 7	RS1/16S123J	C 8	CKSRYB103K25
R 8	RS1/16S332J	C 9	CKSQYB104K16
R 9	RS1/16S473J	C 10	CCSRCKR50C50
R 10	RS1/16S223J	C 11	CEJA1R0M50
R 11	RS1/16S124J	C 13	CKSRYB222K50
R 13	RS1/16S563J	C 14	CCSRCH220J50
R 15	RS1/16S271J	C 16	CCSRCH8R0D50
R 16	RS1/16S104J	C 17	CKSRYB222K50
R 17	RS1/16S332J	C 18	CKSRYB103K25
R 18	RS1/16S332J	C 19	CKSRYB222K50
R 31	RS1/16S470J	C 20	CKSRYB222K50
R 32	RS1/16S822J	C 21	CEJA100M16
R 33	RS1/16S822J	C 22	CCSRTH9R0D50
R 34	RS1/16S331J	C 23	CCSRTH120J50
R 35	RS1/16S331J	C 24	CCSRCH471J50
R 51	RS1/16S271J	C 25	CKSRYB103K25
R 52	RS1/16S560J	C 31	CKSRYB103K25
R 55	RS1/16S102J	C 32	CKSQYB472K50
R 56	RS1/16S823J	C 33	CCSRCH5R0C50
R 61	RS1/16S392J	C 34	CKSQYB104K16
R 62	RS1/16S393J	C 36	CCSRRH201J50
R 101	RS1/16S272J	C 51	CKSRYB223K25
R 102	RS1/16S682J	C 52	CKSRYB103K25
R 103	RS1/16S333J	C 54	CCSRCH470J50
R 104	RS1/16S334J	C 55	CKSQYB223K25
R 105	RS1/16S683J	C 56	CKSQYB104K16
R 107	RS1/16S222J	C 57	CKSRYB472K50
R 151	RS1/16S222J	C 58	CEJA330M10
R 152	RS1/16S393J	C 59	CKSRYB103K25
R 154	RS1/16S104J	C 61	CCSRCH270J50
R 155	RS1/16S273J	C 62	CKSRYB103K25
R 156	RS1/16S243J	C 63	CEJAR15M50
R 157	RS1/16S203J	C 101	CEJANP100M10
R 160	RS1/16S222J	C 102	CKSRYB182K50
R 161	RS1/16S563J	C 103	CKSRYB682K25
R 162	RS1/16S105J	C 104	CEJA2R2M50
R 163	RS1/16S222J	C 105	CKSRYB103K25
R 202	RS1/16S223J	C 106	CCSRCH151J50
R 203	RS1/16S225J	C 107	CKSRYB103K25
R 204	RS1/16S103J	C 151	CKSRYB472K50
R 206	RS1/16S220J	C 152	CKSQYB104K16
R 207	RS1/16S101J	C 153	CEJA3R3M50
R 208	RS1/16S102J	C 154	CKSQYB104K16
R 209	RS1/16S471J	C 157	CEJA3R3M50
R 214	RS1/16S822J	C 158	CKSYB474K16
R 215	RS1/16S822J	C 159	CEJA220M6R3
		C 160	CKSQYB104K16
		C 161	CKSQYB104K16
		C 162	CEJA3R3M50
		C 163	CKSRYB102K50
		C 170	CCSRCH100D50

====Circuit Symbol and No.====Part Name	Part No.
C 201	CCSRCH471J50
C 202	CCSRCH100D50
C 203	CKSRYPB332K50
C 204	CKSQYB473K16
C 205	CKSQYB473K16
C 206	CKSQYB104K16
C 207	CCSRCH560J50
C 209	CKSQYB104K16
C 211	CCSRCH101J50
C 212	CEJA470M6R3
C 213	CKSRYPB103K25
C 216	CCSRCH101J50
C 217	CEJA1R5M50
C 219	CCSRCH471J50
C 220	CKSRYPB103K25
C 230	CKSRYPB103K25
C 231	CCSRCH330J50
C 232	CCSRCH150J50
C 233	CKSQYB104K16
C 234	CEJA330M10
C 235	CKSRYPB332K50
C 236	CKSQYB473K16
C 237	CCSRCH120J50
C 239	CKSRYPB472K50
C 240	CEJAR47M50
C 241	CKSQYB104K16
C 242	CEJAR47M50
C 243	CEJAR33M50
C 244	CKSQYB473K16
C 245	CKSRYPB123K25
C 246	CKSQYB473K16
C 250	CCSRCH471J50

====Circuit Symbol and No.====Part Name Part No.

D Unit Number :
Unit Name : Cassette PCB

S 1	Switch(Load)	ESN1016
S 2	Switch(Mute)	ESN1017
S 3	Switch(FWD/REV)	ESH1006
S 4	Switch(Eject)	ESG1006
R 1		RD1/4HM472J

Miscellaneous Parts List

M 1	Motor Unit	EXA1467
HD 1	Head Assy	EXA1466
FU 951	Fuse 10A	CEK1136

6. ADJUSTMENT

● Connection Diagram

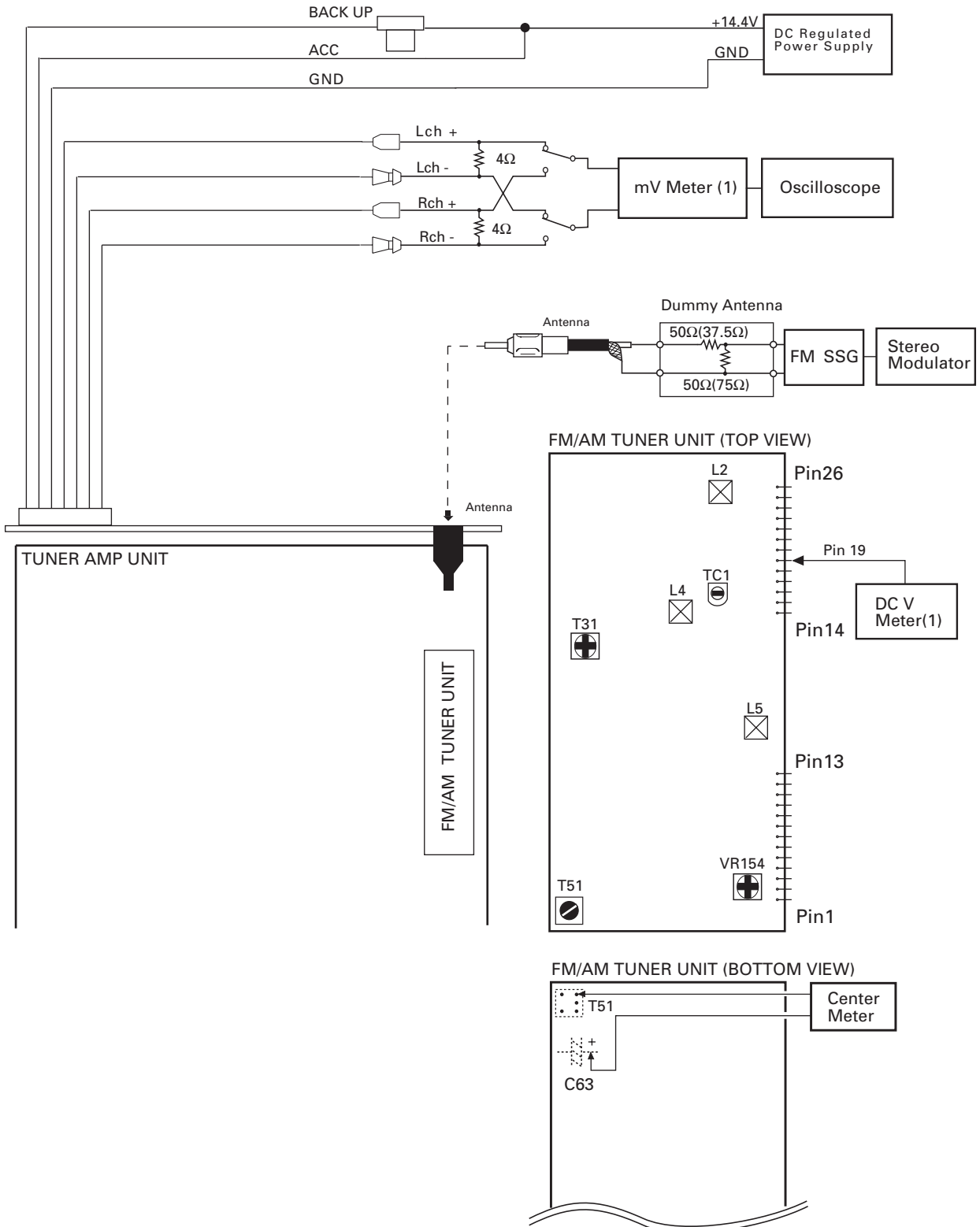

FM ADJUSTMENT

Modulation M:MONO MOD., 400Hz 30%(22.5kHz Dev.) or 400Hz 100%(75kHz Dev.)

S:STEREO MOD., 1kHz, L or R=30%(20.25kHz+7.5kHz Dev.)

NOTE:Before proceeding to further adjustments after switching power ON, let the tuner run for ten minutes to allow the circuits to stabilize.

	No.	FM SSG		Displayed Frequency(MHz)	Adjustment Point	Adjustment Method (Switch Position)
		Frequency(MHz)	Level(dBf)			
TUN Volt	1	108.0	L5	DC V Meter(1) : 6V
IF	2	98.1 M	60—100	98.1	T51	Center Meter : 0
ANT Coil	3	98.1 M	5	98.1	L2	mV Meter(1) : Maximum
RF Coil	4	98.1 M	5	98.1	L4	mV Meter(1) : Maximum
RF Trimmer	5	129.3 M	60—80	107.9	TC1	mV Meter(1) : Minimum
	6	RF Coil and RF Trimmer shall be adjusted twice or more				
IFT	7	98.1 M	5	98.1	T31	mV Meter(1) : Maximum (STEREO MODE)
ARC	8	98.1 S	40	98.1	VR154	mV Meter(1) : Separation 5dB (STEREO MODE)

7. GENERAL INFORMATION

7.1 PARTS

7.1.1 IC

SN761029DL

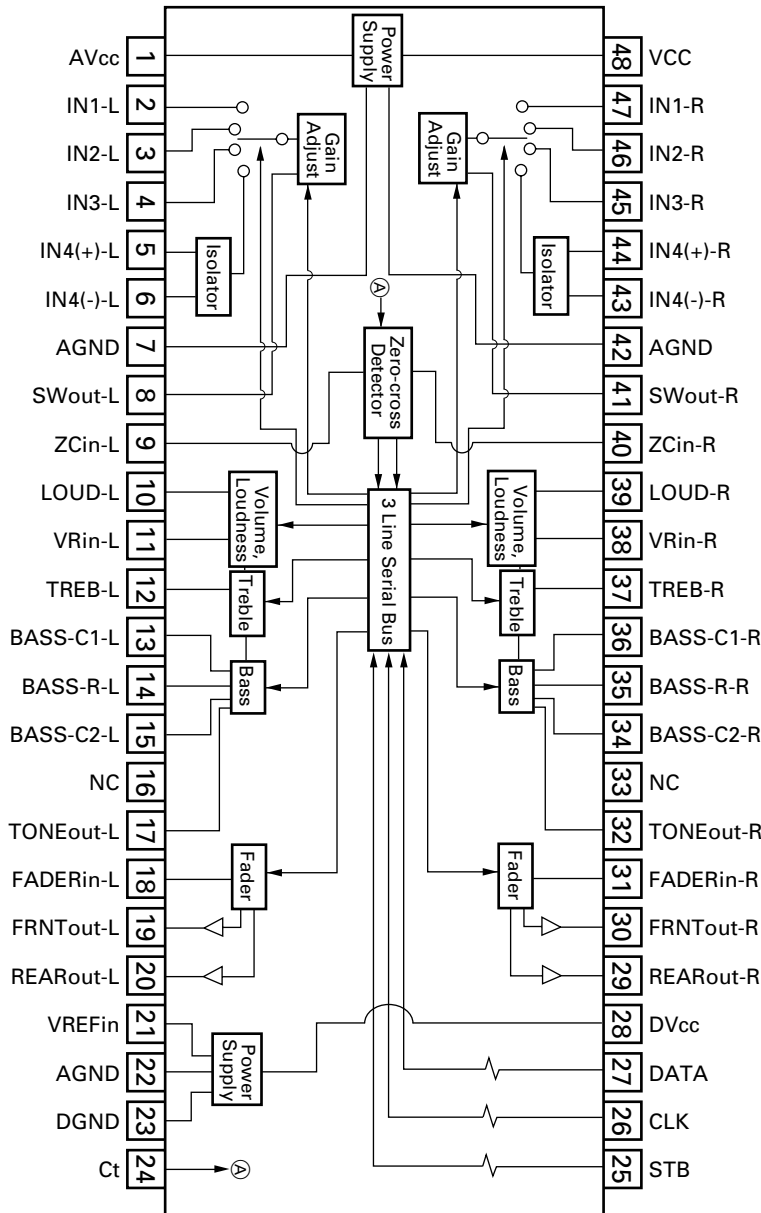

● Pin Functions(PE5017B)

Pin No.	Pin Name	I/O	Format	Function and Operation
1,2	NC			Not used
3	ADPW			A/D converter power
4	GND			GND
5,6	NC			Not used
7	AVREF1			(Connect to VDD)
8	KYDT	I		Key data input
9	DPDT	O	C	Display data output
10	$\overline{\text{DSNS}}$	I		Grille detach sense input
11	TUNPDI	I		PLL IC data input
12	TUNPDO	O	C	PLL IC data output
13	TUNPCK	O	C	PLL IC clock output
14	TUNPCE	O	C	PLL IC chip enable output
15-21	NC			Not used
22	$\overline{\text{SWVDD}}$	O	C	Grille power supply control output
23	NC			Not used
24	VDT	O	C	Data output for electronic volume
25	VCK	O	C	Clock output for electronic volume
26	VST	O	C	Strobe pulse output for electronic volume
27	SYSPW	O	C	System power supply control output
28	$\overline{\text{MUTE}}$	O	C	System mute output
29	DMINH	O	C	Mechanism mute cancel output
30-32	NC			Not used
33	GND			GND
34-37	NC			Not used
38	FM	O	C	FM power control output
39	AM	O	C	AM power control output
40-49	NC			Not used
50	EJECT	I		Eject key input
51	$\overline{\text{TAPLD}}$	I		Tape loading input
52	MECPW	O	C	Cassette mechanism power output
53	$\overline{\text{MCMUT}}$	I		Mechanism mute input
54	$\overline{\text{NOR/REV}}$	I		Normal reverse input
55-59	NC			Not used
60	$\overline{\text{RESET}}$	I		Reset input
61,62	NC			Not used
63	CLKIN	I		Clock input
64	$\overline{\text{ASNS}}$	I		ACC power sense input
65	$\overline{\text{BSNS}}$	I		Back up power sense input
66	SD	I		SD input
67	ST	I		FM stereo input
68	VDD			Power supply
69	X2			Oscillator output
70	X1			Oscillator input
71	GND			GND
72	NC			Not used
73	TESTIN	I		Test program mode input
74	AVDD			A/D converter analog power supply (VDD)
75	AVREF0			(A/D converter standard voltage input)
76	SL	I		Signal level input
77	MODEL	I		Model select input
78-80	NC			Not used

*PE5017B

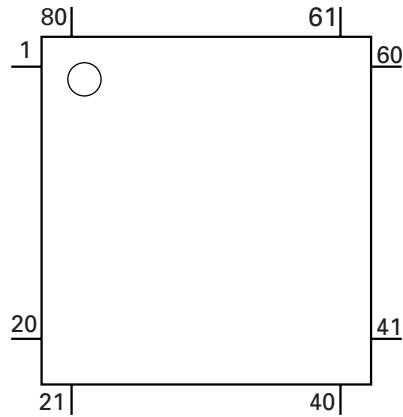

Format	Meaning
C	C MOS

IC's marked by* are MOS type.

Be careful in handling them because they are very liable to be damaged by electrostatic induction.

● Pin Functions (PD6293A)

Pin No.	Pin Name	I/O	Function and Operation
1-5	SEG4-0	O	LCD segment output 4-0
6-8	COM1-3	O	Common driver output 1-3
9	COM0	O	Common driver output 0
10	LCDB		LCD bias power supply
11-14	KS3-0	O	Key strobe output 3-0
15,16	KDT0,1	I	Key data input 0,1
17	REM	I	Remote control reception
18	DPDT	I	Display data input
19	NC		Not used
20	KYDT	O	Key data output
21	MODA		GND
22	X0		Crystal oscillator connection pin
23	X1		Crystal oscillator connection pin
24	VSS		GND
25,26	KDT2,3	I	Key data input 2,3
27,28	KST5,4	O	Key strobe output 5,4
29-55	SEG39-13	O	LCD segment output 39-13
56	VCC		5V
57-64	SEG12-5	O	LCD segment output 12-5

*PD6293A

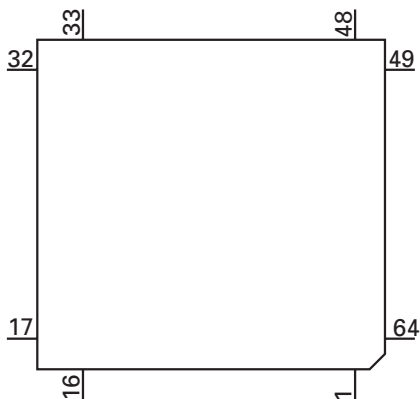

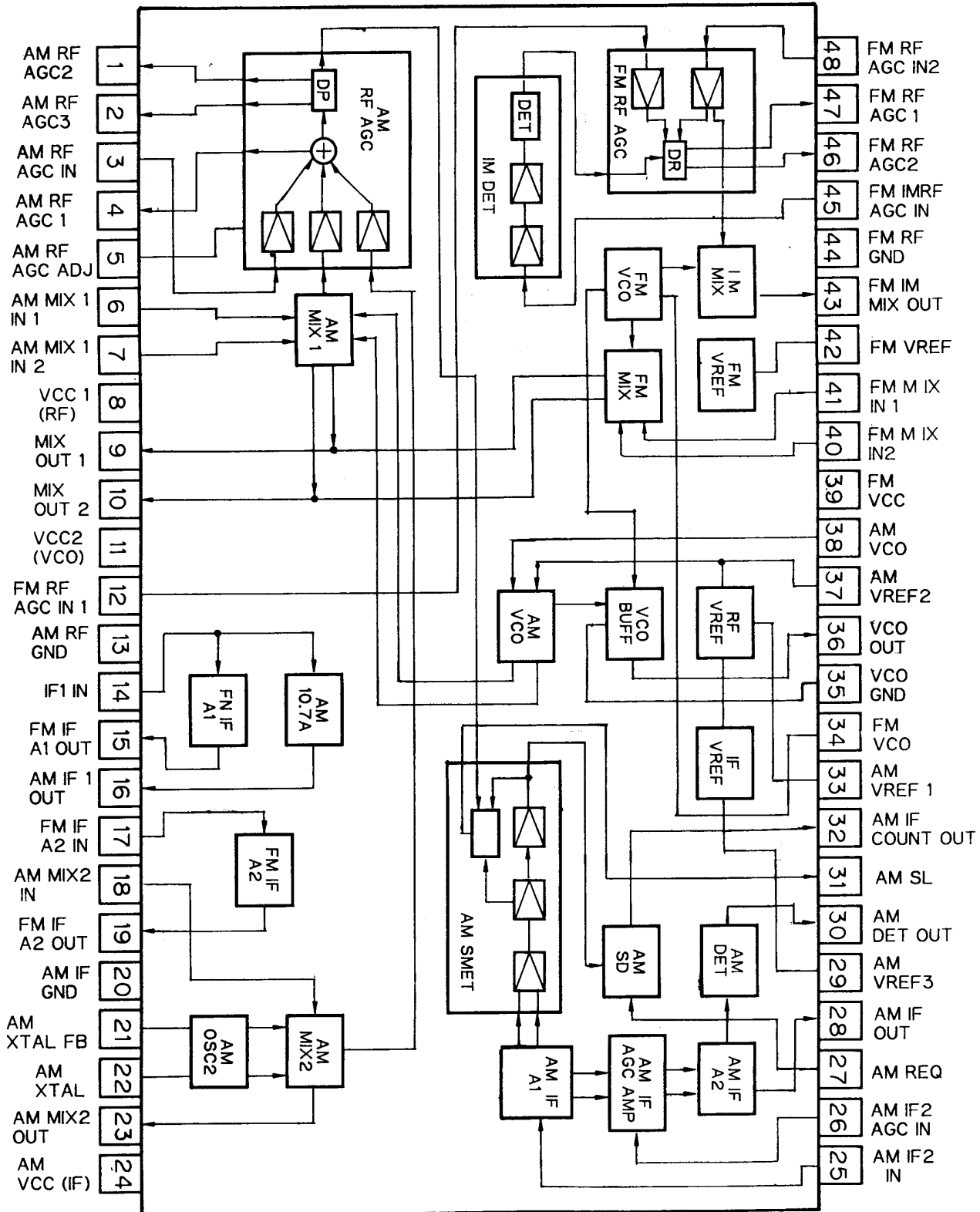

7.1.2 DISPLAY

● CAW1513

SEGMENT

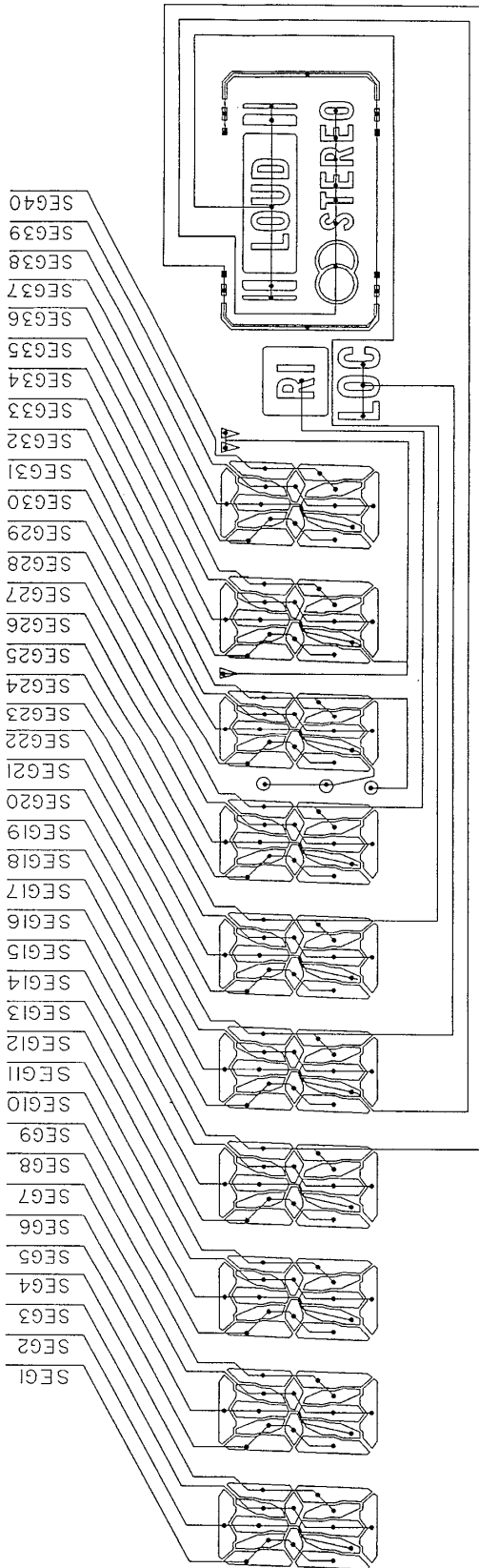

COMMON

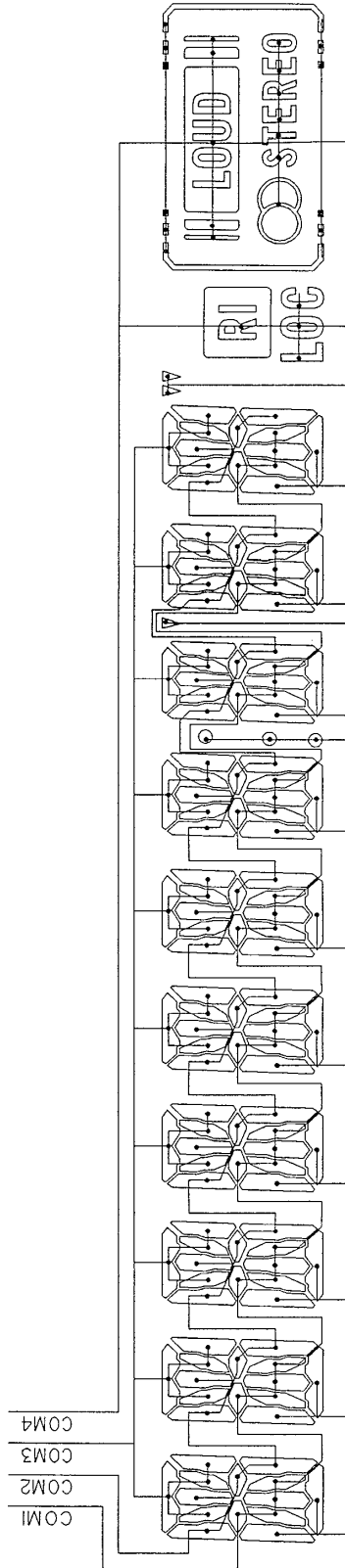

7.2 DISASSEMBLY

● Removing the Case(not shown)

1.Remove the three screws.

2.Remove the Case.

● Removing the Cassette Mechanism Assy (not shown)

1.Remove the four screws.

2.Disconnect the connector, and then removing the Cassette Mechanism Assy.

● Removing the Panel Unit(Fig.1)

1 Disengage the stopper at two locations indicated

2 Remove the Panel Unit.

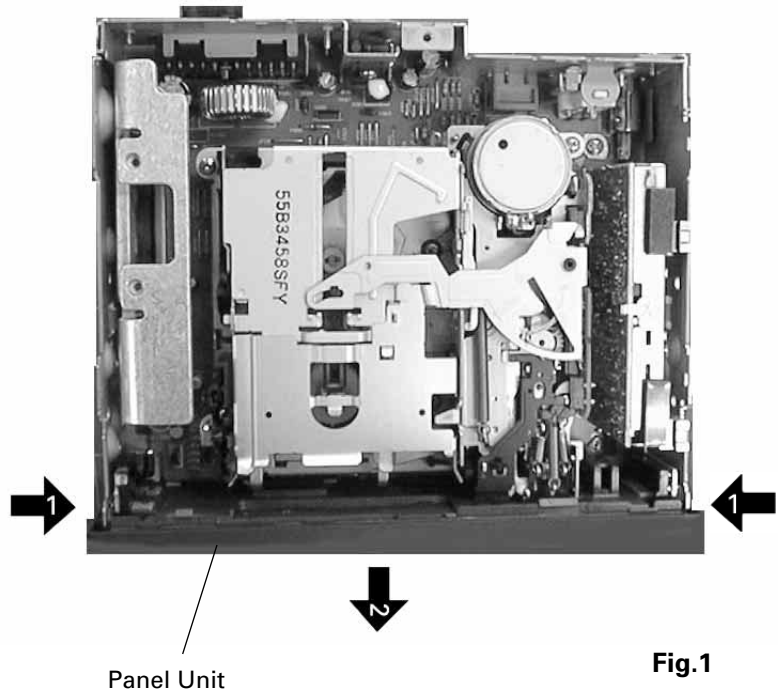

● Removing the Tuner Amp Unit(Fig.2)

1 Removing the two screws.

2 Removing the three screws.

3 Removing the screw.

4 Unbend the tabs at four locations indicated by arrow until straight. Remove the Tuner Amp Unit.

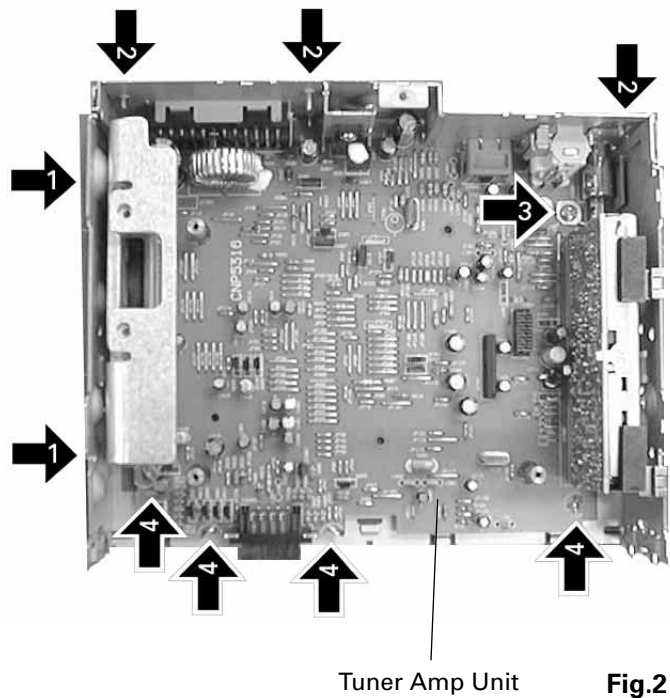

7.3 BLOCK DIAGRAM

● KEH-1800/X1M/EW

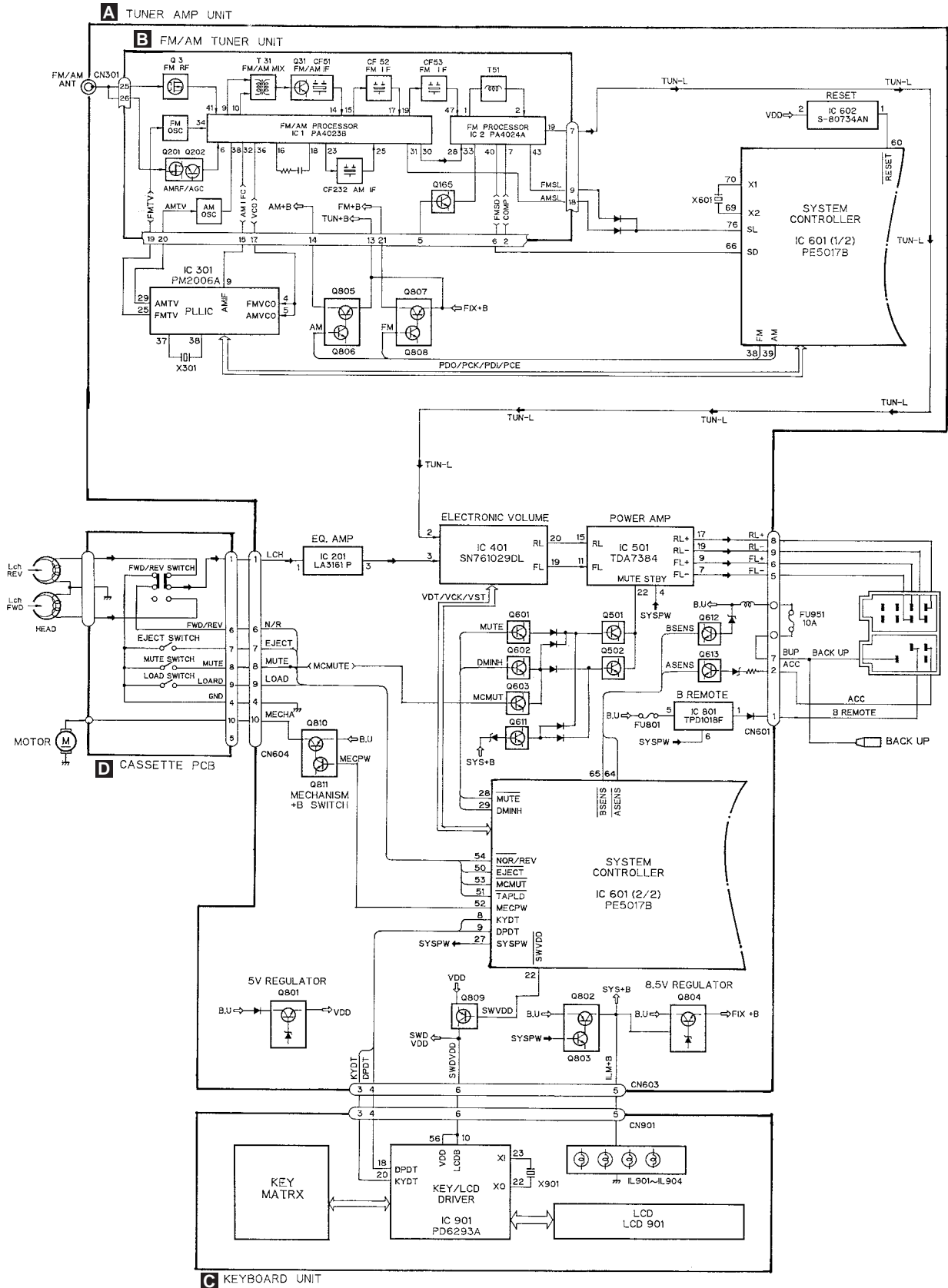

8. OPERATIONS AND SPECIFICATIONS

Connection Diagram

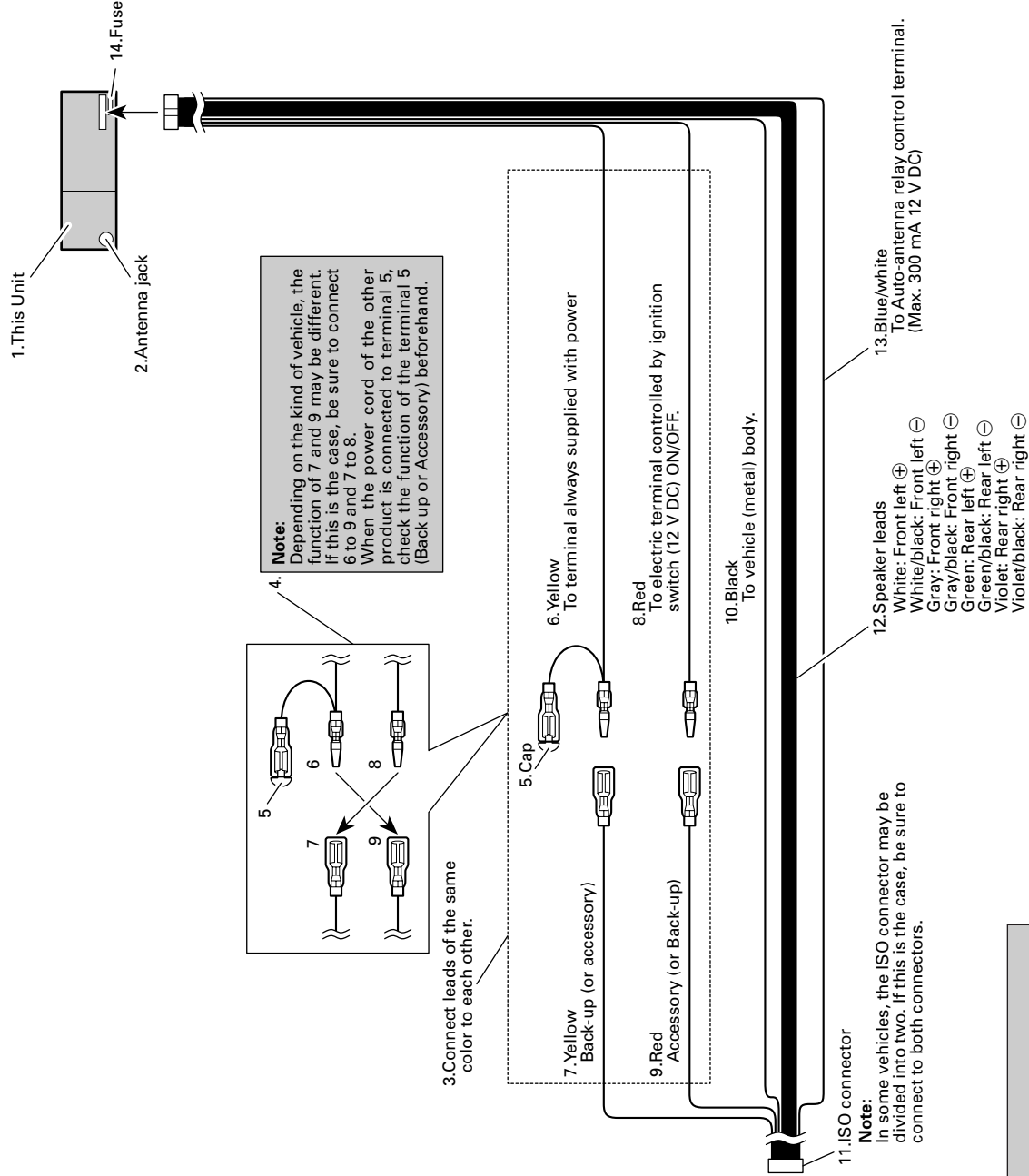

CAUTION

- Cords for this unit and those for other units may be different colors even if they have the same function. When connecting this unit to another unit, refer to the supplied Installation manuals of both units and connect cords that have the same function.

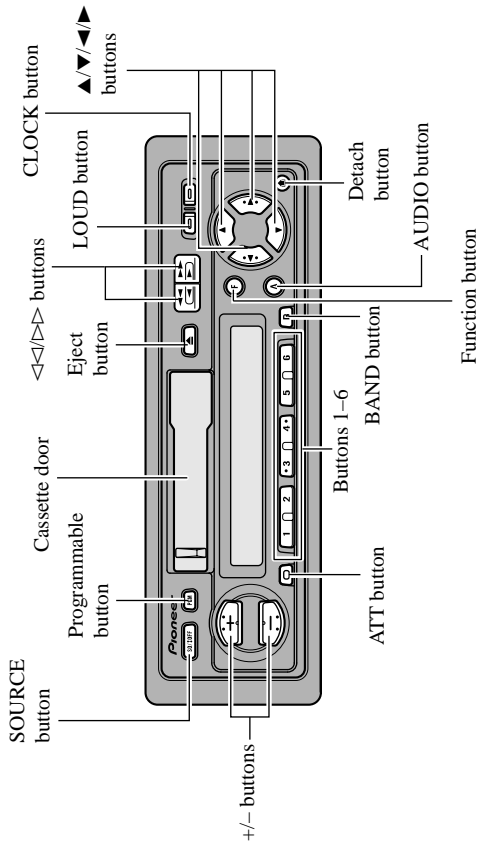

Basic Operation of Cassette Player

1. Insert the cassette tape.

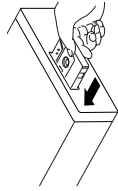

2. Switch tape playback from side A to side B, or vice versa.

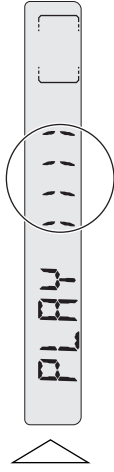

3. Raise or lower the volume.

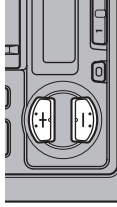

4. Remove the cassette tape.

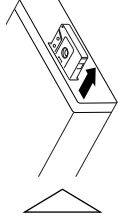

Note:

- The Tape function can be turned ON/OFF with the cassette tape remaining in this product.

Basic Operation of Tuner

1. Select Tuner.

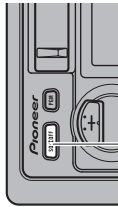

Each press changes the Source ...

The program service name or frequency appears on the display. ("STEREO" indicator lights when a stereo station is selected.)



2. Select the desired band.

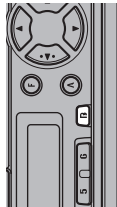

F1 → F11 → F111 → MW/LW

3. Tune the receiver to a higher or lower frequency.

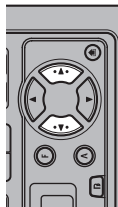

This product's tuner lets you select the tuning by changing the length of the time you press the button.

Manual Tuning (step by step)	0.3 seconds or less
Seek Tuning	0.3 – 2 seconds
Manual Tuning (continuously)	2 seconds or more

Note:

- To select a weak broadcasting station that cannot be tuned in with the Seek Tuning function, tune in with Manual Tuning.

4. Raise or lower the volume.

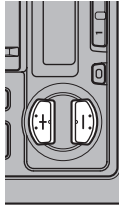

5. Turn the source OFF.

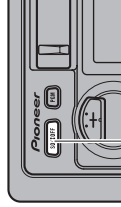

Hold for 1 second

Selecting the Mode

- Select the mode you want to adjust.



Each press changes the Mode ...

Each press of the AUDIO button selects the mode in the following order:
 Fader/Balance → Bass → Treble → Loudness
 When audio modes are selected for adjustment, the setting returns to the normal display after 30 seconds.

Balance Adjustment

This function allows you to select a Fader/Balance setting that provides ideal listening conditions in all occupied seats.

1. Select the Fader/Balance mode.

After adjustment use the BAND button to return to the normal display.

2. Shift the balance progressively to the front or rear speakers.

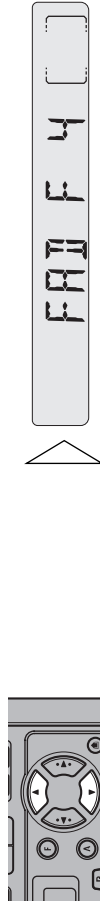

"FAD F15" – "FAD R15" is displayed as it moves from front to rear.

Note:

- "FAD 00" is the proper setting when 2 speakers are in use.

3. Shift the balance to the left or right speaker, respectively.

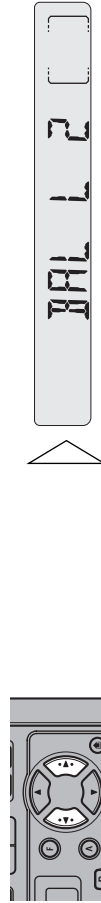

"BAL L9" – "BAL R9" is displayed as it moves from left to right.

Bass/Treble Adjustment

This product is equipped with two tone adjustment modes, the Bass Adjustment and Treble Adjustment modes.

1. Select "Bass Adjustment mode" or "Treble Adjustment mode".
 After adjustment use the BAND button to return to the normal display.
2. Increase or decrease the intensity of the bass or treble, whichever is selected.

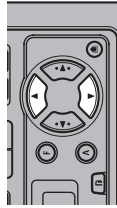

The display shows "+6" – "-6".



3. Repeat steps 1 – 2 above for the other Bass or Treble Adjustment mode.

Loudness Adjustment

The Loudness function compensates for deficiencies in the low and high sound ranges at low volume.

1. Select the Loudness adjustment mode.

After selection use the BAND button to return to the normal display.

2. Switch the Loudness function ON or OFF.

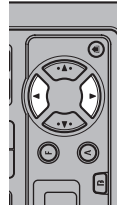

Volume Attenuator

The attenuator reduces the volume instantly.

- Cut the volume by about 90%.

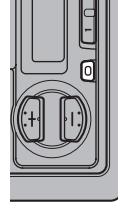

Repeat the preceding operation to return to previous volume.

If the (+) or (-) button is used to cancel the Attenuator mode, the sound will resume at a lower volume than before.

Specifications

General

Power source	14.4 V DC (10.8 – 15.1 V allowable)
Grounding system	Negative type
Max. current consumption	8.5 A
Dimensions	
(mounting size)	178 (W) × 50 (H) × 150 (D) mm
(front face)	188 (W) × 58 (H) × 19 (D) mm
Weight	1.2 kg

Amplifier

Maximum power output	40 W × 4
Continuous power output	22 W × 4
	(DIN45324, +B=14.4 V)
Load impedance	4 Ω (4 – 8 Ω allowable)
Tone controls	
(Bass)	±12 dB (100 Hz)
(Treble)	±12 dB (10 kHz)
Loudness contour	+10 dB (100 Hz), +7 dB (10 kHz)
	(volume: –30 dB)

Cassette player

Tape	Compact cassette tape (C-30 – C-90)
Tape speed	4.76 cm/sec.(+0.14cm/sec.,-0.05cm/sec.)
Fast forward/rewinding time	Approx. 90 sec. for C-60
Wow & flutter	0.13% (WRMS)
Frequency response	40 – 14,000 Hz (±3 dB)
Stereo separation	45 dB
Signal-to-noise ratio	52 dB (IEC-A network)

FM tuner

Frequency range	87.5 – 108 MHz
Usable sensitivity	
.....	11 dBf (1.0 μV/75 Ω, mono, S/N: 30 dB)
50 dB quieting sensitivity	16 dBf (1.7 μV/75 Ω, mono)
Signal-to-noise ratio	70 dB (IEC-A network)
Distortion	0.3% (at 65 dBf, 1 kHz, stereo)
Frequency response	30 – 15,000 Hz (±3 dB)
Stereo separation	40 dB (at 65 dBf, 1 kHz)

MW tuner

Frequency range	531 – 1,602 kHz
Usable sensitivity	18 μV (S/N: 20 dB)
Selectivity	50 dB (±9 kHz)

LW tuner

Frequency range	153 – 281 kHz
Usable sensitivity	30 μV (S/N: 20 dB)
Selectivity	50 dB (±9 kHz)

Note:

- Specifications and the design are subject to possible modification without notice due to improvements.